



**TENDER NO. KP1/9A/5F/OT/005/16-17 FOR THE DESIGN, SUPPLY,
INSTALLATION AND COMMISSIONING OF OPTICAL NETWORK
MANAGEMENT SYSTEM (NMS)**

DATE OF TENDER DOCUMENT JUNE 2017

**ALL TENDERERS ARE ADVISED TO READ CAREFULLY THIS TENDER
DOCUMENT IN ITS ENTIRETY BEFORE MAKING ANY BID**

(OPEN TENDER DOCUMENT FOR SUPPLY, INSTALLATION & COMMISSIONING)

THE KENYA POWER & LIGHTING COMPANY LIMITED
CENTRAL OFFICE, STIMA PLAZA,
KOLOBOT ROAD, PARKLANDS,
P.O. BOX 30099-00100,
NAIROBI,
KENYA.

Telephones: 254-020-3201000; 3644000 Pilot Lines

Telephones: 254 -720-600070/1-5; 733-755001/2-3 Cellular

Website: www.kplc.co.ke

Email Jochieng@kplc.co.ke
dkiniti@kplc.co.ke
Lbalera@kplc.co.ke

Website: www.kplc.co.ke

ABBREVIATIONS AND ACRONYMS

BDS	Bid Data Sheet
BQ	Bill of Quantities
CBK	Central Bank of Kenya
CC	Conditions of Contract
DDP	Delivery Duty Paid
ERC	Energy Regulatory Commission
GoK	Government of Kenya
ICPAK	Institute of Certified Public Accountants of Kenya
JV	Joint Venture
KPLC	The Kenya Power & Lighting Company Limited
KSh./ KES	Kenya Shillings
PM	Project Manager
PPAD 2015	Public Procurement and Asset Disposal Act, 2015
PPRA	Public Procurement Regulatory Authority
VAT	Value Added Tax
NCA	National Construction Authority

TABLE OF CONTENTS

ABBREVIATIONS AND ACRONYMS	1
SECTION I - INVITATION TO TENDER.....	3
SECTION II - TENDER SUBMISSION CHECKLIST.....	5
TABLE OF PARAGRAPHS ON INSTRUCTIONS TO TENDERERS.....	8
SECTION III - INSTRUCTIONS TO TENDERERS (ITT).....	10
SECTION IV - BID DATA SHEET (Appendix to Instructions to Tenderers)	32
SECTION V: SCHEDULE OF REQUIREMENTS.....	33
SECTION VI (a) SCHEDULE OF RATES AND PRICES.....	35
SECTION VI (b) BILL OF QUANTITIES	Error! Bookmark not defined.
SECTION VII - SUMMARY OF EVALUATION PROCESS.....	38
TABLE OF CLAUSES ON GENERAL CONDITIONS OF CONTRACT	45
SECTION VIII 6 GENERAL CONDITIONS OF CONTRACT	47
SECTION IX 6 SPECIAL CONDITIONS OF CONTRACT.....	62
SECTION X - TECHNICAL SPECIFICATIONS.....	62
SECTION XI - DRAWINGS.....	82
SECTION XII - STANDARD FORMS.....	83
SECTION XIII - SUPPLIER EVALUATION FORM.....	118

SECTION I - INVITATION TO TENDER

DATE: JUNE 2017

TENDER NO. KP1/9A/5F/OT/005/16-17 FOR THE DESIGN, SUPPLY, INSTALLATION AND COMMISSIONING OF OPTICAL NETWORK MANAGEMENT SYSTEM (NMS)

1.1 The Kenya Power & Lighting Company Limited hereinafter referred to KPLC invites bids from eligible Tenderers for **Supply, Installation and Commissioning of Optical Network Management System (NMS)**. Interested eligible Tenderers may obtain further information from the General Manager- Supply Chain, The Kenya Power & Lighting Company Ltd at Stima Plaza, 3rd Floor, Kolobot Road, P.O. Box 30099 ó 00100 Nairobi, Kenya.

1.2 Obtaining tender documents.

1.2.1 Tender documents detailing the requirements may be obtained from the KPLC E-Procurement Portal .

1.2.2 Prospective bidders may also download the tender document from KPLC's website (www.kplc.co.ke) free of charge.

1.3 Submission of Tender documents

Completed Tenders are to be submitted in electronic format on the KPLC's E-procurement portal on the due date and time published on the portal. Tenderers are required to visit the portal from time to time for revised closing dates and addendums. The Tender is to be submitted **ONLINE** on or before the submission date and time indicated on the **KPLC tendering portal**.

1.4 Prices

Prices quoted should be inclusive of all taxes and delivery costs to the required site (where applicable) and must be in Kenya Shillings or a freely convertible currency in Kenya and shall remain valid for ninety (90) days from the closing date of the tender. ***Please note that prices indicated on the KPLC tendering portal should be inclusive of VAT.***

1.5 Opening of submitted Tenders

Tenders will be opened promptly thereafter in the presence of the Tenderer's or their representatives who choose to attend in KPLC Auditorium at Stima Plaza, Kolobot Road, Parklands, Nairobi.

1.6 Pre-bid meeting

There will be a pre-bid meeting to be held at KPLC's premises, Stima Plaza, Auditorium, Kolobot Road, Nairobi, Kenya at **10:00 am on 4th July 2017**. Attendance for all prospective bidders is recommended.

SECTION II - TENDER SUBMISSION CHECKLIST

Bidders are advised to clearly label their documents while uploading on the portal. –

No.	Item	Tick Where Provided
1	Tender Security ó Bank Guarantee or Letters of Credit (issued by Banks Licensed by the Central Bank of Kenya), Guarantee by a deposit taking Microfinance Institution, Sacco Society, the Youth Enterprise Development Fund or the Women Enterprise Fund.	
2	Declaration Form	
3	Duly completed Tender Form	
4	Confidential Business Questionnaire (CBQ)	
5	Duly completed Qualification Information Form and the required attachments	
6	Proposed Work Plan (Work method & schedule)	
7	Duly completed Site Visit Form (where applicable)	
8	Copy of Contractorø/Supplierø Certificate of Incorporation	
9	Certificate of Confirmation of Directors and Shareholding (C.R.12) for registered companies and if not a registered company a business name for those trading as a sole proprietor or a partnership registered under the Kenyan law or equivalent certification for foreign tenderers	
10	Copy of Subcontractorø Certificate of Incorporation (where applicable)	
11	Copy of Contractorø/Supplierø Certificate of Registration for the relevant category from the Communications Authority of Kenya ó CAK, Energy Regulatory Commission ERC (<i>and where applicable any other relevant body the User department may deem necessary based on the nature of the work to be carried out by the contractor</i>)	
12	Copy of Subcontractorø Certificate of Registration for the relevant category from the Communications Authority of Kenya ó CAK, Energy Regulatory Commission ERC (<i>and where applicable any other relevant body the User department may deem necessary based on the nature of the work to be carried out by the contractor</i>)	
13*	Copy of Valid Tax Compliance Certificate	
14	Copy of PIN certificate	
15	Type Test Certificates and their Reports and or Test Certificates and their Reports	

16	Copy of accreditation certificate for the testing laboratory as per ISO/ IEC 17025,	
17	Valid and current ISO 9001 Certificates or for locally manufactured or produced goods, valid Mark of Quality Certificate or Standardization Mark Certificates from the Kenya Bureau of Standards (KEBS).	
18	Catalogues and or Manufacturer's drawings	
19	Duly completed Schedule of Guaranteed Technical Particulars	
20	Manufacturer's Authorization and warranty	
21	Names with full contact as well as physical addresses of previous customers of similar works and reference letters from at least four (4) of the customers	
22	Names with full contact as well as physical addresses of previous customers of similar goods and reference letters from at least four (4) of the customers	
23	Statement on Deviations	
24	<i>For foreign tenderers, provide proof that Forty percent (40%) of the supplies are from citizen contractors</i>	
25	Price Schedule and/or Bill of Quantities	
26	Audited Financial Statements. The audited financial statements required must be those that are reported within eighteen (18) calendar months of the date of the tender document. <i>(For companies or firms that are registered or incorporated within the last one calendar year of the Date of the Tender Document, they should submit certified copies of bank statements covering a period of at least six months prior to the date of the tender document. The copies should be certified by the Bank issuing the statements. The certification should be original).</i>	
27	Any other document or item required by the tender document. (The Tenderer shall specify such other documents or items it has submitted)	

***NOTES TO TENDERERS**

1. Valid Tax Compliance Certificate shall be one issued by the relevant tax authorities and valid for at least up to the tender closing date. All Kenyan registered Tenderers must provide a valid Tax Compliance Certificate.
2. *Foreign Tenderers must provide equivalent documents from their country of origin as regards Tax Compliance Certificate OR statements certifying that the equivalent documentation is not issued in the Tenderer's country of origin. The Statement(s) that*

equivalent documentation is not issued by the Tenderer's country should be original and issued by the Tax authorities in the Tenderer's country of origin.

3. Valid Registration Certificate shall be one issued by the relevant body e.g. National Construction Authority (NCA), CAK, ERC.

TABLE OF PARAGRAPHS ON INSTRUCTIONS TO TENDERERS

Paragraph No.	Headings	Page No.
3.1	Definitions	1
3.2	Eligible Tenderers	1
3.3	Eligible Goods	1
3.4	Declarations of Eligibility	1
3.5	Joint Venture	1
3.6	Time for Completion of Works	1
3.7	Source of Funding	1
3.8	Conflict of Interest	1
3.9	One Tender per Tenderer	1
3.10	Site Visit and Pre-Bid Meeting	1
3.11	Cost of Tendering	1
3.12	Contents of the Tender Document	1
3.13	Clarification of Documents	1
3.14	Amendment of Documents	1
3.15	Language of Tender	1
3.16	Documents Comprising the Tender	1
3.17	Tender Forms	1
3.18	Tender Rates and Prices	1
3.19	Tender Currencies	1
3.20	Tenderers' Eligibility and Qualifications	1
3.21	Eligibility and Conformity of Works to Tender Documents	1
3.22	Demonstration(s), Inspection(s) and Test(s)	1
3.23	Warranty	1
3.24	Tender Security	1
3.25	Validity of Tenders	1
3.26	Alternative Offers	1
3.27	Preparation and Signing of The Tender	1
3.28	Deadline for Submission of Tender	1
3.29	Modification and Withdrawal of Tenders	1
3.30	Opening of Tenders	1
3.31	Process To Be Confidential	1
3.32	Clarification of Tenders and Contacting KPLC	1
3.33	Preliminary Tender Evaluation	1
3.34	Minor Deviations, Errors or Oversights	1
3.35	Technical Evaluation and Comparison of Tenders	1
3.36	Financial Evaluation of Tenders	1
3.37	Preferences	1

3.38 Debarment of a Tenderer í í í í í í .í í í í .

3.39 Confirmation of Qualification for Award í í í í í í ...

3.40 Award of contract í .í í í í í í í í í í í í í í í í í

3.41 Termination of Procurement Proceedingsí í í í í í í í ..í

3.42 Notification of Awardí í í í í í í í í í í í í í í í í í .

3.43 Clarifications with the Successful Tenderer (s)í í í í í í í í í í ..

3.44 Signing of Contractí í í í í í í í í í í í í í í í í í í í

3.45 Performance Security í í í í í í í í í í í í í í í í í í .

3.46 Corrupt or Fraudulent Practicesí í ..í í í í í í í í í í í í í

SECTION III - INSTRUCTIONS TO TENDERERS (ITT)

3.1 Definitions

In this tender, unless the context or express provision otherwise requires: -

- a) *Any reference to any Act shall include any statutory extension, amendment, modification, re-amendment or replacement of such Act and any rule, regulation or order made there-under.*
- b) *“Date of Tender Document” shall be the **start date** specified on the KPLC tendering portal.*
- c) *“Day” means calendar day and “month” means calendar month.*
- d) *“KEBS” wherever appearing means the Kenya Bureau of Standards or its successor(s) and assign(s) where the context so admits.*
- e) *“KENAS” wherever appearing means the Kenya National Accreditation Service or its successor(s) and assign(s) where the context so admits*
- f) *“NCA” wherever appearing means the National Construction Authority or its successor(s) and assign(s) where the context so admits*
- g) *“PPRA” wherever appearing means The Public Procurement Regulatory Authority or its successor(s) and assign(s) where the context so admits.*
- h) *Reference to “the tender” or the “Tender Document” includes its appendices and documents mentioned hereunder and any reference to this tender or to any other document includes a reference to the other document as varied supplemented and/or replaced in any manner from time to time.*
- i) *“The Procuring Entity” means The Kenya Power and Lighting Company Limited or its successor(s) and assign(s) where the context so admits (hereinafter abbreviated as KPLC).*
- j) *“The Tenderer” means the person(s) submitting its Tender for the performance of Works in response to the Invitation to Tender. This may include a business name, joint venture, private or public company, government owned institution or any combination of one or more of them.*
- k) *Where there are two or more persons included in the expression the “Tenderer”, any act or default or omission by the Tenderer shall be deemed to be an act, default or omission by any one or more of such persons.*
- l) *Words importing the masculine gender only, include the feminine gender or (as the case may be) the neutral gender.*
- m) *Words importing the singular number only include the plural number and vice-versa and where there are two or more persons included in the expression the “Tenderer” the covenants, agreements and obligations expressed to be made or performed by the Tenderer shall be deemed to be made or performed by such persons jointly and severally.*
- n) *“Works” means the construction, repair, renovation or demolition of*

buildings, roads or other structures and includes the design, supply, installation, testing and commissioning of equipment and materials, site preparation and other incidental services where applicable.

- m) KPLC's "authorised person" shall mean its MD & CEO who is designated by the PPAD Act 2015 to exercise such power, authority or discretion as is required under the tender and any contract arising therefrom, or such other KPLC staff delegated with such authority.*
- n) Citizen contractors-a firm shall be qualified as a citizen contractor if its owners and shareholders are Kenyan citizens*
- o) Local contractors- a firm shall be qualified as a local contractor if it is registered in Kenya.*

3.2 Eligible Tenderers

- 3.2.1 This Invitation to Tender is open to all Tenderers eligible as described in the **Bid Data Sheet** (Appendix to Instructions to Tenderers). Successful Tenderers shall perform the Works in accordance with this tender and the ensuing contract.
- 3.2.2 Agreements between undertaking to directly or indirectly fix purchase or selling prices or any other trading conditions are prohibited. Where this is discovered, the undertakings involved will not be eligible for award and all undertakings involved shall be disqualified.
- 3.2.3 The classification of eligibility shall be in accordance with that maintained by Kenya's NCA or its successor responsible for the classification of contractors.
- 3.2.4 Government or government owned institutions in Kenya may participate only if they are legally and financially autonomous, if they operate under commercial law, are registered by the relevant registration board or authorities and if they are not a dependant agency of the Government.
- 3.2.5 All Tenderers shall comply with all relevant licensing and/or registration requirements with the appropriate statutory bodies in Kenya such as the NCA, the ERC, the National Treasury, the County Treasury or any other relevant authority.
- 3.2.6 Tenderers shall provide such evidence of their continued eligibility satisfactory to KPLC as KPLC may reasonably request.
- 3.2.7 Tenderers (including all members of a joint venture and subcontractors) shall provide a statement that they are not associated, or have not been associated in the past, directly or indirectly, with the Consultant or any other entity that has prepared the design, specifications, and other documents for this project or being proposed as Project Manager for this Contract. A firm that has been engaged by the Employer to provide consulting services for the preparation or supervision of the Works, and any of its affiliates, shall not be eligible to tender
- 3.2.8 For purposes of this paragraph the Tenderer shall submit with its Tender, a valid copy of certificate of Confirmation of Directorships and Shareholding issued **and signed** by either the Registrar of Companies or Registrar of Business Names. This certificate

must not be more than three (3) months old from the Date of the Tender Document. KPLC reserves the right to subject the certificate to authentication.

3.2.9 In addition a tenderer is eligible to bid for this contract only if the tenderer satisfies the following criteria

- (a) the tenderer has the legal capacity to enter into a contract for procurement or asset disposal;*
- (b) the tenderer is not insolvent, in receivership, bankrupt or in the process of being wound up;*
- (c) the tenderer, if a member of a regulated profession, has satisfied all the professional requirements;*
- (d) the tenderer and his or her sub-contractor, if any, is not debarred;*
- (e) the tenderer has fulfilled tax obligations;*
- (f) the tenderer has not been convicted of corrupt or fraudulent practices; and*
- (g) is not guilty of any serious violation of fair employment laws and practices.*

3.3 Ineligible Tenderers

3.3.1 Notwithstanding any other provisions of this tender, the following are not eligible to participate in the tender:-

- a) KPLC's employees, its Board or any of its committee members.
- b) Any Cabinet Secretary of the Government of the Republic of Kenya (GoK)
- c) Any public servant of GoK.
- d) Any member of a Board or Committee or any department of GoK.
- e) Any person appointed to any position by the President of Kenya.
- f) Any person appointed to any position by any Cabinet Secretary of GoK.

3.3.2 In addition the tenderer shall be considered ineligible to bid, where in case of a corporation, private company, partnership or other body, the tenderer, their spouse, child or sub-contractor has substantial or controlling interest and is found to be in contravention of the provisions of section 3.2.9 above.

3.3.3 Despite the provisions of section 3.3.1 and 3.3.2, a tenderer having a substantial or controlling interest shall be eligible to bid where

- (a) such tenderer has declared any conflict of interest; and
- (b) performance and price competition for that good, work or service is not available or can only be sourced from that tenderer.

3.3.4 For the purposes of this paragraph, any relative i.e. spouse(s) and child(ren) of any person mentioned in sub-paragraph 3.3.1 is also ineligible to participate in the tender. In addition, a Cabinet Secretary shall include the President, Deputy-President or the Attorney General of GoK.

3.3.5 Tenderers shall provide the qualification information statement that the Tenderer (including all members of a joint venture and subcontractors) is not associated, or have been associated in the past, directly or indirectly, with a firm or any of its affiliates which have been engaged by KPLC to provide consulting services for the

preparation of the design, specifications, and other documents to be used for the procurement of the goods under this Invitation to Tender.

- 3.3.6 Tenderers shall not be under declarations as prescribed at Section XIII
- 3.3.7 Tenderers who are not under these declarations shall complete the Declaration Form strictly in the form and content as prescribed at Section XIII.
- 3.3.8 Those that are under the Declaration as prescribed at Section XIII whether currently or in the past shall not complete the Form. They will submit a suitable Form giving details, the nature and present status of their circumstances.

3.4 Declarations of Eligibility

- 3.4.1 Tenderers shall not be under declarations of ineligibility for corrupt, fraudulent practices and are not amongst persons mentioned in sub-paragraphs 3.3.1, 3.3.2 and 3.3.4 above.
- 3.4.2 Tenderers who are not under these declarations shall complete the Declaration Form strictly in the form and content as prescribed at Section XIII.
- 3.4.3 Those that are under the Declaration for corrupt and fraudulent practices whether currently or in the past shall not complete the Form. They will submit a suitable Form giving details, the nature and present status of their circumstances.

3.5 Joint Venture

- 3.5.1 Tenders submitted by a joint venture (JV) of two or more firms (consortium), as partners shall comply with the following requirements: -
 - a) The Tender Form and in case of a successful tender, the Contract Agreement Form, shall be signed so as to be legally binding on all partners of the joint venture.
 - b) One of the partners shall be nominated and authorized as being lead contractor. The authorization shall be evidenced by submitting a Power of Attorney signed by legally authorized signatories of all the partners/directors.
 - c) The Power of Attorney which shall accompany the tender, shall be granted by the authorized signatories of all the partners as follows:-
 - (i) for local and citizen contractors, before a Commissioner of Oaths or a Notary Public or Magistrate of the Kenyan Judiciary.
 - (ii) for a foreign bidder, before a Notary Public, or the equivalent of a Notary Public, and in this regard the bidder shall provide satisfactory proof of such equivalence.
 - d) The lead contractor shall be authorized to incur liability and receive instructions for and on behalf of any and all the partners of the joint

venture and the entire execution of the contract including payment shall be done exclusively with the lead contractor.

- 3.5.2 All partners of the joint venture shall be liable jointly and severally for the execution of the contract in accordance with the contract terms, and a relevant statement to this

effect shall be included in the authorization mentioned in paragraph 3.5.1 (b) above as well as in the Form of Tender and the Contract Agreement Form (in case of the accepted tender).

3.5.3 The JV must be in either of the following forms ó

- a) A registered JV agreement. The registration may either be :-
 - (i.) At the Ministry of Transport, Infrastructure, Housing and Urban Development or,
 - (ii.) At the Office of the Attorney General, or
 - (iii.) NCA
- b) A Letter of Intent to enter into a joint venture including a draft JV Agreement indicating at least the part of the Works to be executed by the respective partners.
- c) The JV agreement should be signed by at least two directors from each company or firm that is a party to the JV
- d) The JV agreement must be under the company or firm seal
- e) The Letter of Intent should be signed by at least one director from each company or firm that is a party to the intended joint venture

3.5.4 A copy of the agreement entered into, or Letter of Intent by the joint venture partners shall be submitted with the tender.

3.6 Time for Completion of Works

The successful Tenderer will be expected to complete the Works by the required completion period as specified in the BDS.

3.7 Source of Funding

KPLC has set aside funds during the present financial year. It is intended that part of the proceeds of funds will be applied to cover the eligible payments under the ensuing contract for these Works.

3.8 Conflict of Interest

3.8.1 A Tenderer (*including all members of a joint venture and subcontractors*) shall not have a conflict of interest. A Tenderer found to have a conflict of interest shall be disqualified. A Tenderer may be considered to have a conflict of interest with one or more parties in this tendering process if they:-

- a) are associated or have been associated in the past directly or indirectly with employees or agents of KPLC or a member of the Board or committee of KPLC
- b) are associated or have been associated in the past directly or indirectly with a firm or company or any of their affiliates which have been engaged by KPLC to provide consulting services for the preparation of the design, specifications, and other documents to be used for the execution, completion and maintenance of the Works under this Invitation to Tender

- c) have controlling shareholders in common with (b) above
 - d) receive or have received any direct or indirect subsidy from any of them
 - e) have a relationship with each other, either directly or through common third parties, that puts them in a position to have access to information about, or influence on the tender of another Tenderer, or influence the decisions of KPLC regarding this tendering process
 - f) submit more than one Tender in this tendering process.
- 3.8.2 A Tenderer will be considered to have a conflict of interest if they participated as a consultant in the preparation of the design or technical specification of the Works and related services that are the subject of this Tender.

3.9 One Tender per Tenderer

- 3.9.1 A firm or company shall submit only one Tender in the same tendering process, either individually or as a partner in a joint venture.
- 3.9.2 No firm or company can be a sub-contractor while submitting a Tender individually or as a partner in a joint venture in the same tendering process.
- 3.9.3 A company or firm, if acting in the capacity of sub-contractor in any Tender may participate in more than one Tender but only in that capacity.
- 3.9.4 A Tenderer who submits or participates in more than one tender (*other than as a sub-contractor or in cases of alternatives that have been permitted or requested*) will cause all tenders in which the Tenderer has participated to be disqualified.

3.10 Site Visit and Pre-Bid Meeting

- 3.10.1 The Tenderer, at the Tenderer's own responsibility and risk is advised to visit and examine the site of Works and its surrounding and obtain all information that may be necessary for preparing the tender and entering into a contract for the Works. The cost of visiting the site shall be at the Tenderer's own expense.
- 3.10.2 KPLC may conduct a site visit and pre-bid meeting. The purpose of the pre-bid meeting shall be to clarify issues and answer any questions that may be raised at that stage.
- 3.10.3 The Tenderer's designated representative is invited to attend a site visit and pre-bid meeting which if convened will take place at the venue and time stipulated in the BDS.
- 3.10.4 The Tenderer is requested as far as possible to submit any questions in writing or by electronic means to reach KPLC before the pre-bid meeting.
- 3.10.5 Minutes of the pre-bid meeting including the text of the questions raised and the responses given together with any response prepared after the pre-bid meeting will be transmitted within the time stated in the BDS to all purchasers of the Tender Document.
- 3.10.6 Non-attendance during the site visit or the pre-bid meeting will not be a cause of disqualification of the Tender unless specified to the contrary in the BDS.

3.11 Cost of Tendering

3.11.1 The Tenderer shall bear all costs associated with the preparation and submission of its Tender. KPLC will in no case be responsible or liable for those costs, regardless of the conduct or outcome of the tendering process.

3.12 Contents of the Tender Document

3.12.1 The Tender Document comprises the documents listed below and Addendum (where applicable) issued in accordance with paragraph 3.14 of these Instructions to Tenderers: -

- a) *Invitation to Tender*
- b) *Tender Submission Checklist*
- c) *Instructions to Tenderers*
- d) *Bid Data Sheet*
- e) *Schedule of Requirements*
- f) *Bill of Quantities*
- g) *Summary of Evaluation Process/Evaluation Criteria*
- h) *General Conditions of Contract*
- i) *Special Conditions of Contract s*
- j) *Technical Specifications*
- k) *Drawings*
- l) *Tender Form*
- m) *Confidential Business Questionnaire Form*
- n) *Manufacturer's Authorization Form*
- o) *Manufacturer's Warranty*
- p) *Tender Security Forms*
- q) *Declaration Form*
- r) *Contract Agreement Form*
- s) *Performance Security Forms*
- t) *Proposed Work Program (Work method & schedule)*

3.12.2 The Tenderer is expected to examine all instructions, forms, provisions, terms and specifications in the Tender Document. Failure to furnish all information required by the Tender Document or to submit a tender not substantially responsive to the Tender Document in every respect will be at the Tenderer's risk and may result in the rejection of its Tender.

3.12.3 All recipients of the documents for the proposed Contract for the purpose of submitting a tender (whether they submit a tender or not) shall treat the details of the documents as "Private and Confidential".

3.13 Clarification of Documents

A prospective Tenderer requiring any clarification of the Tender Document may notify the General Manager Supply Chain in writing and ensure receipt is

acknowledged at KPLC's Physical address indicated on the Tender Document. KPLC will respond in writing to any request for clarification of the Tender documents, which it receives not later than seven (7) days prior to the deadline for the submission of Tenders, prescribed by KPLC. Written copies of KPLC's response (*including an explanation of the query but without identifying the source of inquiry*) will be published and accessible to all prospective Tenderers on the KPLC's tendering portal.

3.14 Amendment of Documents

- 3.14.1 At any time prior to the deadline for submission of Tenders, KPLC, for any reason, whether at its own initiative or in response to a clarification requested by a prospective Tenderer, may modify the tender documents by amendment.
- 3.14.2 All prospective Tenderers that have registered in the portal for the Tender will be notified of the amendment(s) (*hereinafter referred to or otherwise known as addendum*) in writing and will be binding on them.
- 3.14.3 In order to allow prospective Tenderers reasonable time in which to take the amendment into account in preparing their Tenders, KPLC, at its discretion, may extend the deadline for the submission of Tenders.

3.15 Language of Tender

The Tender prepared by the Tenderer, as well as all correspondence and documents relating to the tender, exchanged between the Tenderer and KPLC, shall be written in English language, provided that any printed literature furnished by the Tenderer may be written in another language provided that they are accompanied by an accurate English translation of the relevant passages in which case, for purposes of interpretation of the Tender, the English translation shall govern. The English translation shall be on the Tenderer's letterhead and shall be signed by the duly authorized signatory signing the Tender and stamped with the Tenderer's stamp.

3.16 Documents Comprising the Tender

The Tender prepared and submitted by the Tenderers shall include but not be limited to all the following components: -

- a) *Declaration Form, Tender Form and Priced Bill of Quantities (BQ) duly completed*
- b) *Documentary evidence that the Works and any ancillary services thereto to be performed by the Tenderer conform to the tender documents*
- c) *Technical Proposal in sufficient detail to demonstrate the adequacy of the Tenderer's proposal to meet the Works requirements and the completion time. Those details should include the following: -*
 - (i.) *a statement of work methods and schedule i.e. Methodology*
 - (ii.) *major items of equipment proposed to carry out the Contract*

- (iii) *an undertaking that the items in c (ii) will be available for the execution of the Contract.*
- d) *Tender Security furnished in accordance with the Tender requirements*
- e) *Power of Attorney authorizing the signatory of the Tender to commit the Tenderer in accordance with the Tender requirements.*
- f) *A detailed list of previous clients as prescribed in the BDS for similar Works on tender and their contact addresses including e-mail shall be submitted with the Tender for the purpose of reference, or for evaluation*
- g) *Statement of Deviations, if any, from the tender requirements on a separate sheet of paper clearly indicating –*
 - (i.) *the specific tender document requirement*
 - (ii.) *the deviation proposed by the Tenderer*
 - (iii.) *the technical specifications of the deviation*
 - (iv.) *the design, if any, of the deviation*
 - (v.) *justification or reason for the deviation*
 - (vi.) *the Tenderer's cost of that deviation and the Tenderer's estimate of the cost of complying with KPLC's requirement without the deviation.*
- h) *In case of a tender submitted by a joint venture, either of the following –*
 - (i.) *the registered joint venture agreement, or,*
 - (ii.) *a Letter of Intent to enter into a joint venture including a draft JV agreement indicating at least the part of the Works to be executed by the respective partners.*
- j) *Any information or other materials required to be completed and submitted by Tenderers as specified in the Tender Document*

3.17 Tender Forms

The Tenderer shall complete and sign the Tender Form and all other documents furnished in the Tender Document, indicating the Works to be performed, a brief description of the Works, quantities, and prices amongst other information required.

3.18 Tender Rates and Prices

- 3.18.1 The Tenderer shall indicate on the Price Schedule and/or Bill of Quantities, the unit rates and prices (where applicable) and total tender price of the Works it proposes to perform under the contract.
- 3.18.2 The Tenderer shall fill in rates and prices for all items of the Works described in the Price Schedule and/or BQs. Items for which no rates or price is entered by the Tenderer will not be paid for by KPLC when executed and shall be deemed covered by other rates and prices in the Price Schedule and/or BQs.
- 3.18.3 Prices and rates indicated on the Price Schedule and/or BQs shall be inclusive of all costs for the Works including insurances, duties, levies, Value Added Tax (V.A.T), Withholding Tax and other taxes payable and delivery to the premises of KPLC (where applicable) or other specified site(s). No other basis shall be accepted for evaluation, award or otherwise.

- 3.18.4 Price Schedule and/or BQ rates and prices to be submitted (quoted) by the Tenderer shall remain fixed for the contract duration.
- 3.18.5 For the avoidance of doubt, Tenderers shall quote on Delivered Duty Paid (*DDP*) basis. No other basis shall be accepted for evaluation, award or otherwise.
- 3.18.6 Section 20 of the Insurance Act Cap 487 requires all imports to the country to be insured with a local insurance company. It is now mandatory for all marine cargo imports to adhere to this requirement.
- 3.18.7 A price that is derived by a disclosed incorporation or usage of an internationally accepted standard formula shall be acceptable within the meaning of this paragraph.

3.19 Tender Currencies

- 3.19.1 For Works that the Tenderer will provide from within or outside Kenya, the prices shall be quoted in Kenya Shillings, or in another freely convertible currency in Kenya. The currency quoted must be indicated clearly on the Price Schedule and/or BQs.
- 3.19.2 The exchange rate to be used for currency conversion for evaluation purposes shall be the Central Bank of Kenya selling rate prevailing on the Tender closing date. (*Please visit the Central Bank of Kenya website*).

3.20 Tenderer's Eligibility and Qualifications

- 3.20.1 Pursuant to paragraph 3.2, the Tenderer shall furnish, as part of its Tender, documents establishing the Tenderer's eligibility to tender and its qualifications to execute, complete and maintain the Works in the contract if its Tender is accepted.
- 3.20.2 The documentary evidence of the Tenderer's qualifications to perform the contract if its Tender is accepted shall be established to KPLC's satisfaction ó
- a) *that, in the case of a Tenderer offering to supply goods under the contract which the Tenderer did not manufacture or otherwise produce, the Tenderer has been duly authorized by the goods' manufacturer or producer to supply the goods. The authorization shall strictly be in the form and content as prescribed in the Manufacturer's Authorization Form in the Tender Document.*
- b) *that the Tenderer has the financial capability necessary to perform the contract. The Tenderer shall be required to provide -*
- (i.) *Audited Financial Statements (Audited Accounts) that are reported within eighteen (18) calendar months of the date of the tender document. The Statements must be stamped and signed by the Auditors who must be currently registered by ICPAK.*
- (ii.) *For companies or firms that are registered or incorporated within the last one calendar year of the Date of the Tender Document, they should submit certified copies of bank statements covering a period of at least six (6) months prior to the Date of the Tender Document. The copies should be certified by the Bank issuing the statements. The certification should be original.*

- (iv.) *A valid and current Tax Compliance Certificate (TCC) issued by KRA. The Tenderer is strongly advised to confirm the authenticity of the TCC with KRA's Compliance Department to avoid rejection of its Tender.*
- (iv.) *evidence of adequacy of working capital for this Contract eg. access to line(s) of credit and availability of other financial resources*
- c) *that the Tenderer has the technical and/or production capability necessary to perform the contract.*
- d) *that, in the case of a Tenderer not doing business within Kenya, the Tenderer is or will be (if awarded the contract) represented by an agent in Kenya equipped and able to carry out the Tenderer's maintenance, repair, spare parts and stocking obligations prescribed in the Conditions of Contract and or in the Technical Specifications.*
- e) *that the Tenderer has the technical and management capability necessary to perform the contract. These are as per the Qualification Information Form which includes: -*
 - (i.) *documents showing qualifications and experience of key site management and technical personnel proposed for the Contract.*
 - (ii.) *employment records including contracts of employment for all key personnel*
 - (v.) *The Tenderer's undertaking that the key site management and technical personnel will be available for the contract*
 - (vi.) *List and evidence of ownership/lease of contractor's equipment proposed for carrying out the Works*
- f) *that the Tenderer is duly classified and currently registered by NCA, ERC, the National Treasury, the County Treasury or any other relevant authorised body as capable of performing the Works under the contract. The Tenderer will furnish KPLC with a copy of the registration certificate and copy of renewal receipt. KPLC reserves the right to subject the certificate and receipt to authentication.*
- g) *information regarding any litigation or arbitration current or during the last five (5) years, in which the Tenderer is involved, the parties concerned and disputed amount; and*
- h) *detailed proposals for subcontracting components of the Works amounting to more than twenty percent (20%) of the Contract Price.*
- f) *tenderer's confirmation that at least forty percent (40%) of their supplies is sourced from citizen contractors, where applicable.*

3.20.3 Tenderers with a record of unsatisfactory or default in performance obligations in any contract shall not be considered for evaluation or award. For the avoidance of doubt,

this shall include any Tenderer with unresolved case(s) in its obligations for more than two (2) months in any contract.

3.21 Eligibility and Conformity of Works to Tender Documents

3.21.1 The Tenderer shall furnish, as part of its tender, documents establishing the eligibility and conformity to the Tender Document of all the Works that the Tenderer proposes to perform under the contract.

3.21.2 The documentary evidence of the eligibility of the goods shall consist of a statement in the Price Schedule of the country of origin of the goods and services offered which shall be confirmed by a certificate of origin issued at the time of shipment.

3.21.3 The documentary evidence of conformity of the Works to the Tender Document may be in the form of literature, drawings, and data, and shall (where applicable) consist of: -

- a) *a detailed description of the essential technical and performance characteristics of the Works whether in brochures, catalogues, drawings or otherwise,*
- b) *a list giving full particulars, including available source and current prices of spare parts, special tools and other incidental apparatus necessary for the proper and continuing performance of the Works for a minimum period of six (6) months following usage of the Works after the official handing over to KPLC, and,*
- c) *Duly completed Schedule of Guaranteed Technical Particulars (GTP) as per Tender Specifications demonstrating substantial responsiveness of the goods and service to those specifications and, if any, a statement of deviations and exceptions to the provisions of the Technical Specifications.*
- d) *duly completed Price Schedule and/or BQs' in compliance with KPLC's schedule of requirements and/or BQs requirements or, a Statement of Deviations and exceptions to the provisions of KPLC's schedule of requirements and/or BQs' requirements.*

For (a), (b) and (c) above, the literature, drawings and data shall be those from the Manufacturer.

3.21.4 For purposes of the documentary and other evidence to be furnished pursuant to subparagraphs 3.21.1, 3.21.2 and paragraph 3.22, the Tenderer shall note that standards for workmanship, material, and equipment, designated by KPLC in its schedule of requirements and/or BQs are intended to be descriptive only and not restrictive. The Tenderer may adopt higher standards in its Tender, provided that it demonstrates to KPLC's satisfaction that the substitutions ensure substantial equivalence to those designated in the BQs.

3.22 Demonstration(s), Inspection(s) and Test(s)

- 3.22.1 Where required, all Tenderers shall demonstrate ability of performance of the required Works in conformity with the schedule of requirements and/or Bills of Quantities.
- 3.22.2 KPLC or its representative(s) shall have the right to inspect/ test the Tenderer's capacity, equipment, premises, and to confirm their conformity to the tender requirements. This shall include the quality management system. KPLC's representative(s) retained for these purposes shall provide appropriate identification at the time of such inspection/ test.
- 3.22.3 The bidder shall meet the cost of demonstration, inspection and test while KPLC shall meet the cost of air travel to the nearest airport and accommodation of its nominated officers inspecting and witnessing tests. Where conducted on the premises of the Tenderer(s), all reasonable facilities and assistance, including access to drawings and production data, shall be furnished to the inspectors at no charge to KPLC. In all cases, the equipment used for tests must be validly calibrated by the national standards body and a copy (ies) of the calibration certificate(s) must be submitted with the test report(s).
- 3.22.4 Demonstration and/or Inspection and/or Test Report(s) shall be completed upon conclusion of the demonstration/ inspection/ tests. This Report will be considered at time of evaluation and or award.

3.23 Warranty

- 3.23.1 Where required in the Tender, all Tenderers must also provide a Warranty that warrants that any part of the Works that comprises any equipment, the equipment to be provided under the contract are new, unused and or are of the most recent or current specification and incorporate all recent improvements in design and materials unless provided otherwise in the Tender.
- 3.23.2 The Warranty shall also warrant that the equipment in the Tenderer's bid have no defect arising from manufacture, materials or workmanship or from any act or omission of the Tenderer that may develop under normal use or application of the equipment under the conditions obtaining in Kenya.
- 3.23.3 This warranty will remain valid for the period indicated in the special conditions of contract after the goods, or any portion thereof as the case may be, have been delivered, installed and commissioned at the final destination indicated in the contract.

3.24 Tender Security

- 3.24.1 The Tenderer shall furnish, as part of its Tender, a tender security for the amount specified in the BDS. The Original Tender Security, in a clearly labelled envelop, shall be deposited in the Tender Security Box on 3rd Floor, Stima Plaza on or before the opening date and time and receipt acknowledged by KPLC evidenced by a stamped copy.
- 3.24.2 The tender security shall be either one or a combination of the following: -

- a) an original Bank Guarantee from a commercial bank licensed by the Central Bank of Kenya (CBK) that is strictly in the form and content as prescribed in the Tender Security Form (Bank Guarantee) in the Tender Document. The bank must be located in Kenya.
 - b) For local bidders, Standby Letters of Credit (LC). All costs, expenses and charges levied by all banks party to the LC shall be prepaid/borne by the Tenderer. The LC must contain all the mandatory conditions of payment to KPLC as prescribed in the Tender Security (Letters of Credit) provided in the Tender Document.
 - c) For foreign bidders, Standby Letters of Credit (LC) confirmed by a bank in Kenya. All costs, expenses and charges levied by all banks party to the LC including confirmation charges shall be prepaid/borne by the Tenderer. The LC must contain all the mandatory conditions of payment to KPLC as prescribed in the Tender Security (Letters of Credit) provided in the Tender Document.
 - d) An original Guarantee by a deposit taking Microfinance Institution, Sacco Society, Youth Enterprise Development Fund or the Women Enterprise Fund, that is strictly in the form and content as prescribed in the Tender Security Form
- 3.24.3 The Tender Security is required to protect KPLC against the risk of the Tenderer's conduct which would warrant the security's forfeiture pursuant to paragraph 3.24.10.
- 3.24.4 The Tender Security shall be denominated in Kenya Shillings or in another freely convertible currency, and shall be issued by a commercial bank located in Kenya and licensed by the Central Bank of Kenya or a deposit taking Microfinance Institution, Sacco Society, Youth Enterprise Development Fund or the Women Enterprise Fund. The bank or institution must be located in Kenya.
- 3.24.5 The Tender Security shall be valid for thirty (30) days beyond the validity of the tender.
- 3.24.6 KPLC shall seek authentication of the Tender Security from the issuing bank. It is the responsibility of the Tenderer to sensitise its issuing bank/institution on the need to respond directly and expeditiously to queries from KPLC. The period for response shall not exceed five (5) days from the date of KPLC's query. Should there be no conclusive response by the bank/institution within this period, such Tenderer's Tender Security may be deemed as invalid and the bid rejected.
- 3.24.7 Any Tender not secured in accordance with this paragraph will be rejected by KPLC as non-responsive, pursuant to paragraph 3.35.
- 3.24.8 The unsuccessful Tenderer's Tender Security will be released as promptly as possible, in any of the following circumstances: -
- a) *the procurement proceedings are terminated*
 - b) *KPLC determines that none of the submitted Tenders is responsive*
 - c) *a contract for the procurement is entered into*

3.24.9 The successful Tenderer's Tender Security will be released upon the successful Tenderer's signing the contract, pursuant to paragraph 3.44 and furnishing an authentic Performance Security, pursuant to paragraph 3.24.

3.24.10 The Tender Security shall be forfeited if

- a) *if the Tenderer withdraws its Tender after the deadline for submitting Tenders but before the expiry of the period during which the Tenders must remain valid*
- b) *if the Tenderer fails to enter into a written contract in accordance with paragraph 3.44*
- c) *if the successful Tenderer fails to furnish the performance security in accordance with paragraph 3.24*
- d) *if the Tenderer fails to extend the validity of the tender security where KPLC has extended the tender validity period in accordance with paragraph 3.25.*

3.24.11 In cases of a JV bid, without prejudice to the provisions relating to a JV, the Tender Security may be in the name of any or all parties to the JV and the above provisions on Tender Security shall apply.

3.25 Validity of Tenders

3.25.1 Tenders shall remain valid for one hundred and twenty (120) days after the date of tender opening as specified in the Invitation to Tender or as otherwise may be prescribed by KPLC, pursuant to paragraph 3.29. A Tender that is valid for a shorter period shall be rejected by KPLC as non-responsive.

3.25.2 In exceptional circumstances, KPLC may extend the Tender validity period. The extension shall be made in writing. The tender security provided under paragraph 3.25 shall also be extended. A Tenderer shall not be required nor permitted to modify its tender during the extended period.

3.26 Alternative Offers

Only main offers shall be considered, as alternative offers are not acceptable.

3.27 Preparation and Signing of the Tender

3.27.1 The Original and all copies of the Tender shall be typed or written in indelible ink. They shall be signed by the Tenderer or a person or persons duly authorized to bind the Tenderer to the contract.

3.27.2 The authorization shall be indicated by a written Power of Attorney granted by the Tenderer to the authorized person before any of the following persons:-

- a) *For local Tenderers, a Commissioner of Oaths or a Notary Public or a Magistrate of the Kenyan Judiciary.*
- b) *For foreign Tenderers, a Notary Public in the country of the Tenderer.*

In either case above, the Power of Attorney shall accompany the Tender.

- 3.27.3 All pages of the Tender, including un-amended printed literature, shall be initialled by the person or persons signing the Tender and serially numbered.
- 3.27.4 The Tender shall have no interlineations, erasures, or overwriting except as necessary to correct errors made by the Tenderer, in which case such corrections shall be initialled by the person or persons signing the Tender.
- 3.27.5 KPLC will assume no responsibility whatsoever for the Tenderer's failure to comply with or observe the entire contents of paragraph 3.21.
- 3.27.6 Any Tender not prepared and signed in accordance with this paragraph may be rejected by KPLC as non-responsive, pursuant to this paragraph 3.27.

3.28 Deadline for Submission of Tenders

- 3.28.1 Tenders must be received by KPLC by the date and time specified in KPLC's tendering portal in PDF form.
- 3.28.2 KPLC may, at its discretion, extend this deadline for submission of Tenders by amending the tender documents in accordance with paragraph 3.14, in which case all rights and obligations of KPLC and the Tenderer previously subject to the initial deadline, will therefore be subject to the deadline as extended.

3.29 Modification and Withdrawal of Tenders

- 3.29.1 The Tenderer may modify or withdraw its Tender after it has submitted it, provided that written notice of the modification, including substitution or withdrawal of the Tender is received by KPLC prior to the deadline prescribed for submission of tenders.
- 3.29.2 No Tender may be modified after the deadline for submission of Tenders.
- 3.29.3 No Tender may be withdrawn in the interval between the deadline for submission of tenders and the expiration of the period during which the Tender must remain valid. Any withdrawal of a Tender during this interval shall result in forfeiture of the Tenderer's Tender Security.

3.30 Opening of Tenders

- 3.30.1 KPLC shall open all Tenders promptly at the date and time specified in the KPLC tendering portal and at the location specified in the Invitation to Tender or as may otherwise be indicated.
- 3.30.2 The Tenderer's names, tender modifications or withdrawals, the presence or absence of requisite Tender Security and such other details as KPLC, at its discretion, may consider appropriate, will be announced at the opening.
- 3.30.3 At the Tender opening, tender prices, discounts, and such other details as KPLC, at its discretion, may consider appropriate will be read out.
- 3.30.4 The Tenderers or their representatives may attend the opening and those present shall sign a register evidencing their attendance.

3.31 Process to be Confidential

- 3.31.1 After the opening of tenders, information relating to the examination, clarification, evaluation and comparisons of tenders and recommendations arising there-from shall not be disclosed to a Tenderer or other person(s) not officially concerned with such process until conclusion of that process.
- 3.31.2 Conclusion of that process shall be deemed to have occurred, at the latest, by the date and time KPLC notifies the successful bidder(s). In any event, official disclosure by KPLC of any information upon conclusion of that process may only be to the unsuccessful bidders and may contain only the information permissible by law in summary form.
- 3.31.3 Any effort by a Tenderer to influence KPLC or any of its staff members in the process of examination, evaluation and comparison of tenders and information or decisions concerning award of Contract may result in the rejection of the Tenderer's tender.

3.32 Clarification of Tenders and Contacting KPLC

- 3.32.1 To assist in the examination, evaluation and comparison of Tenders KPLC may, at its discretion, ask the Tenderer for a clarification of its Tender. The request for clarification and the response shall be in writing, and no change in the prices or substance of the Tender shall be sought, offered, or permitted.
- 3.32.2 The Tenderer is required to provide timely clarification or substantiation of the information that is essential for effective evaluation of its qualifications. It is the responsibility of the Tenderer to provide in writing the clarification or substantiation which should reach KPLC within five (5) days from the date of KPLC's query. Such writing may include by electronic mail or postal mail. Should there be no conclusive response within this period, it shall result in the Tenderer's disqualification.
- 3.32.3 Save as is provided in this paragraph and paragraph 3.13 above, no Tenderer shall contact KPLC on any matter related to its Tender, from the time of the tender opening to the time the contract is awarded.
- 3.32.4 Any effort by a Tenderer to influence KPLC in its decisions on tender evaluation, tender comparison, tender recommendation(s) or contract award may result in the rejection of the Tenderer's Tender.

3.33 Preliminary Tender Evaluation

- 3.33.1 Prior to the detailed Technical and Financial evaluation, KPLC will determine the substantial responsiveness of each Tender. For purposes of this tender, a substantially responsive Tender is one that conforms to the requirements of Preliminary Evaluation. KPLC's determination of a Tender's responsiveness is to be based on the contents of the Tender itself without recourse to extrinsic evidence.
- 3.33.2 KPLC will examine the Tenders to determine whether they conform to the Preliminary Evaluation Criteria set out in Section VI Evaluation Criteria.
- 3.33.3 Notwithstanding the contents of the foregoing sub-paragraphs, if a Tender is not substantially responsive, it will be rejected at the earliest stage of evaluation by KPLC

and cannot subsequently be made responsive by the Tenderer by correction of any nonconformity.

3.34 Minor Deviations, Errors or Oversights

- 3.34.1 KPLC may waive any minor deviation in a Tender that does not materially depart from the requirements of the goods and or services set out in the Tender Document.
- 3.34.2 Such minor deviation -
 - 3.34.2.1 *shall be quantified to the extent possible,*
 - 3.34.2.2 *shall be taken into account in the evaluation process, and,*
 - 3.34.2.3 *shall be applied uniformly and consistently to all qualified Tenders duly received by KPLC.*
- 3.34.3 KPLC may waive errors and oversights that can be corrected without affecting the substance of the Tender.

3.35 Technical Evaluation and Comparison of Tenders

- 3.35.1 KPLC will further evaluate and compare the Tenders that have been determined to be substantially responsive, in compliance to the Schedule of Requirements and/or BQs set out in the Tender Document and as per the prescribed Evaluation Criteria.
- 3.35.2 The Implementation Plan is a critical aspect of the Tender. KPLC requires that the Works shall be performed at the time specified in the BDS. KPLC's evaluation of a tender will also take into account the Work Plan proposed in the Tender.

3.36 Financial Evaluation

- 3.36.1 The financial evaluation and comparison shall be as set out in the Summary of Evaluation Process. The comparison shall include:-
 - a) the rates and prices [which must be inclusive of insurances, duties, levies, Value Added Tax (V.A.T), Withholding Tax and other taxes payable (where applicable) and delivery to the premises of KPLC (where applicable) or other specified site(s)]
 - b) Confirming if there are any deviations in the Payment Schedule from what is specified in the Special Conditions of Contract
- 3.36.2 Where other currencies are used, KPLC will convert those currencies to the same currency using the selling exchange rate prevailing on the date of tender closing provided by the Central Bank of Kenya.

3.37 Preferences

- 3.37.1 Subject to availability and realization of the applicable international or local standards, only such manufactured articles, materials or supplies wholly mined and produced in Kenya shall be subject to preferential procurement.
- 3.37.2 Despite the above provisions, preference shall be given to

- (a) manufactured articles, materials and supplies partially mined or produced in Kenya or where applicable have been assembled in Kenya; or
- (b) firms where Kenyans are shareholders.

3.37.3 The threshold for the provision under 3.37.2 (b) shall be above fifty-one percent of Kenyan shareholders.

3.37.4 Where a person is entitled to more than one preference scheme, the scheme with the highest advantage to the person shall be applied.

3.37.5 In the evaluation of tenders, exclusive preference shall be given to citizen contractors where the amount of the tender as evaluated is below KShs. 500 Million in respect of works.

3.37.6 For purposes of this paragraph the Tenderer shall submit with its Tender, the following documents:-

- a) a valid copy of certificate or letter of Confirmation of Ownership or Partnerships and Shareholding (CR12) issued and signed by the Registrar of Companies or Registrar of Business Names both of the Office of the Attorney General of Kenya.
- b) The certificate must not be more than three (3) months old from the Date of the Tender Document. KPLC reserves the right to subject the certificate to authentication.
- c) A copy of the Memorandum and Articles of Association of the company
- d) In JV, sub-contracting or other contractual arrangements, copies of the Memorandum and Articles of Association of each company in the JV, sub-contracting or other contractual arrangements.

3.38 Debarment of a Tenderer

A Tenderer who gives false information in the Tender about its qualification or who refuses to enter into a contract after notification of contract award shall be considered for debarment from participating in future public procurement.

3.39 Confirmation of Qualification for Award

3.39.1 KPLC may confirm to its satisfaction whether the Tenderer that is selected as having submitted the lowest evaluated responsive tender is qualified to perform the contract satisfactorily.

3.39.2 The confirmation will take into account the Tenderer's financial, technical, and performance capabilities. It will be based upon an examination of the documentary evidence of the Tenderer's qualifications submitted by the Tenderer, pursuant to paragraph 3.20 as well as confirmation of such other information as KPLC deems necessary and appropriate. This may include factory, office and other facilities inspection and audits.

3.39.3 An affirmative confirmation will be a prerequisite for award of the contract to the Tenderer. A negative confirmation will result in rejection of the Tenderer's Tender, in which event KPLC will proceed to the next lowest evaluated responsive tender to make a similar confirmation of that Tenderer's capabilities to perform satisfactorily.

3.40 Award of Contract

3.40.1 KPLC will award the contract to the successful Tenderer whose Tender has been determined to be substantially responsive, compliant with the evaluation criteria and has been determined to be the lowest evaluated tender, and further, where deemed necessary, that the Tenderer is confirmed to be qualified to perform the contract satisfactorily.

3.41 Termination of Procurement Proceedings

3.41.1 KPLC may at any time terminate procurement proceedings before contract award and shall not be liable to any person for the termination.

3.41.2 KPLC shall give prompt notice of the termination to the Tenderers, and, on request from any Tenderer, give its reasons for termination within fourteen (14) days of such request.

3.42 Notification of Award

3.42.1 Prior to the expiration of the period of tender validity, KPLC shall notify the successful Tenderer in writing that its Tender has been accepted.

3.42.2 The notification of award shall not constitute the formation of the contract until one is finally signed by both parties.

3.42.3 Simultaneously, and without prejudice to the contents of paragraph 3.42, on issuance of Notification of Award to the successful Tenderer, KPLC shall notify each unsuccessful Tenderer.

3.42.4 A notification of the tender outcome does not reduce the validity period for any tender security whether the Tenderer is successful or not, except where such tender security is officially released to the Bank/institution and/or the Tenderer and such Bank/institution discharged of all its obligations by KPLC prior to the expiry of its stated validity period.

3.43 Clarifications with the Successful Tenderer (s)

3.43.1 Clarifications may be undertaken with the successful Tenderer(s) relating to any or all of the following areas:-

- a) A minor alteration to the technical details of the Schedule of requirements and/or BQs
- b) Reduction of quantities for budgetary reasons where the reduction is in excess of any provided for in the Tender Document
- c) A minor amendment to the SCC.
- d) Finalising payment arrangements

- e) Mobilisation arrangements e.g. operational details
- f) Agreed final delivery or Work Plan to accommodate any changes required by KPLC.
- g) Methodology and Staffing
- h) Clarifying details that were not apparent or could not be finalized at the time of tendering

3.43.2 Clarifications shall not change the substance of the Tender.

3.44 Signing of Contract

3.44.1 At the same time as KPLC notifies the successful Tenderer that its Tender has been accepted, KPLC will send the Tenderer the Contract Agreement provided in the Tender Document together with any other necessary documents incorporating all agreements between the Parties.

3.44.2 Within fourteen (14) days of the date of notification of award, the successful Tenderer shall only sign the Contract Form and all the documents specified in that Form and return them to KPLC within that period of fourteen (14) days.

3.44.3 KPLC shall sign and date the Contract not earlier than fourteen (14) days from the date of notification of contract award. Further, KPLC shall not sign the contract until and unless the authentic performance security is received in accordance with paragraph 3.45.

3.44.4 Failure of the successful Tenderer to sign the Contract, the award shall be annulled and its tender security forfeited in which event KPLC shall notify the next lowest evaluated Tenderer that its Tender has been accepted.

3.44.5 Paragraph 3.45 together with the provisions of paragraph 3.44 will apply with necessary modifications with respect to the Tenderer notified under this subparagraph 3.42.4.

3.45 Performance Security

3.45.1 Within fourteen (14) days of the date of notification of award from KPLC, the successful Tenderer shall furnish KPLC with a Performance Security. The Performance Security shall be denominated in Kenya Shillings and shall be valid shall be until a date sixty (60) days beyond the date of issue of the Certificate of Completion.

3.45.2 The Performance Security shall be either one or a combination of the following:

- a) An original Bank Guarantee from a commercial bank licensed by the Central Bank of Kenya that is strictly in the form and content as prescribed in the Performance Security Form (Bank Guarantee) in the Tender Document. The bank issuing the Bank Guarantee must be located in Kenya.
- b) For Local bidders, Standby Letters of Credit (LC). All costs, expenses and charges levied by all banks party to the LC shall be prepaid/borne by the Tenderer. The LC must contain all the mandatory conditions of payment to

KPLC as prescribed in the Tender Security (Letters of Credit) provided in the Tender Document.

- c) For Foreign bidders, Standby Letters of Credit (LC) confirmed by a bank in Kenya. All costs, expenses and charges levied by all banks party to the LC including confirmation charges shall be prepaid/borne by the Tenderer. The LC must contain all the mandatory conditions of payment to KPLC as prescribed in the Tender Security (Letters of Credit) provided in the Tender Document.
- 3.45.3 The successful Tenderer shall furnish a Performance Security being the sum of ten percent (10%) of the contract price.
- 3.45.4 KPLC shall seek authentication of the Performance Security from the issuing bank. It is the responsibility of the successful Tenderer to sensitise its issuing bank on the need to respond directly and expeditiously to queries from KPLC. The period for response shall not exceed three (3) days from the date of KPLC's query. Should there be no conclusive response by the Bank within this period, such successful Tenderer's Performance Security may be deemed as invalid.
- 3.45.5 Failure of the successful Tenderer to furnish an authentic Performance Security, the award shall be annulled and the Tender Security forfeited, in which event KPLC may notify the next lowest evaluated Tenderer that its Tender has been accepted.
- 3.45.6 Without prejudice to sub-paragraph 3.45.5, failure of the successful Tenderer to furnish an authentic Performance Security, during the existence of a running Contract, the Performance Security of the running Contract shall be liquidated by KPLC before expiry of the same.

3.46 Corrupt or Fraudulent Practices

- 3.46.1 KPLC requires that Tenderers observe the highest standard of ethics during the procurement process and execution of contracts. When used in the present Regulations, the following terms are defined as follows: -
 - a) *“Corrupt practice” means the offering, giving, receiving or soliciting of any thing of value to influence the action of public official in the procurement process or in contract execution;*
 - b) *“Fraudulent practice” means a misrepresentation of facts in order to influence a procurement process or the execution of a contract to the detriment of KPLC, and includes collusive practice among Tenderers (prior to or after Tender submission) designed to establish tender prices at artificial non-competitive levels and to deprive KPLC of the benefits of free and open competition.*
- 3.46.2 KPLC will reject a proposal for award if it determines that the Tenderer recommended for award has engaged in corrupt or fraudulent practices in competing for the contract in question.
- 3.46.3 Further, a Tenderer who is found to have indulged in corrupt or fraudulent practices risks being debarred from participating in public procurement in Kenya.

SECTION IV - BID DATA SHEET (Appendix to Instructions to Tenderers)

The following information regarding the tender shall complement and or amend the provisions of the Instructions to Tenderers *hereinafter abbreviated as ITT*. Wherever there is a conflict between the provisions of the ITT and the Bid Data Sheet, the provisions of the BDS shall prevail over those of the ITT.

No.	ITT Reference Clause	Particulars of Appendix
1.	3.2.1 Eligible Tenderers	<i>Local Bidders</i>
2.	3.6 Time for Completion of works	<i>Contractor to provide Works Program. (a) To indicate start and End date of the project as per delivery schedule (b) Indicate work methodology of major components</i>
3.	3.10.3 Site Visit and Pre-Bid Meeting	<i>a) Pre-Bid Meeting on 4th July 2017 at Stima Plaza Auditorium Parklands Nairobi at 10:00 Am. b) Site Visit(s) shall be held after the pre-bid meeting.</i>
	3.10.6 Attendance of pre-bid meeting or site visit	<i>a) The pre-bid meeting is mandatory b) The site visit will be mandatory</i>
4.	3.16(f) – List of Previous Customers	<i>The Tenderer shall submit at least Three (3) names with full contact including telephone, email and physical addresses of previous clients of similar Works and letters from the previous clients confirming satisfactory completion of the contracts and on schedule.</i>
5.	3.20 Documents of evidence of eligibility and qualification	<i>Fiber optic Association (FOA) certifications or equivalent, Engineering degree in Telecom or equivalent, Registration with relevant professional / regulatory bodies,</i>
7.	3.21.3 (a) Catalogues, Manufacturer's/ Principal's Drawings	<i>Proposed Network design diagrams, Equipment Manuals, Data Sheets, Manufacturers Compliance Certifications, Authorization forms, Certificates of conformity, Calibration certificates,</i>
8	3.22.4 Demonstration and/or Inspection and/or Test Report(s)	<i>Factory Acceptance Test at the Manufacturers premises.</i>

9.	3.23.3 Warranty/Warranty Period	<i>Please indicate the period of Warranty if different from that in the ITT. (Three (3) Warranty - TBC</i>
10.	3.24.1 Tender Security	<i>Ksh 500,000</i>
11	3.25 Validity of Tenders	<i>One Hundred and Twenty (120) days</i>
12	3.42 Award of contract	<i>Shall Be for Design, Supply, Installation and Commissioning as One Whole Contract</i>

SECTION V: SCHEDULE OF REQUIREMENTS

Item No.	BRIEF DESCRIPTION	UNIT OF MEASURE	QUANTITY
1	Supply of Fiber Network Management System (NMS) complete with all accessories, hardware, software and licenses for (Server, RTU(s), Switches, Cabinets etc.)	Lot	1
2	Graphic Display as per specification	PC	1
3	Desktop Computer as per specification	PC	3
4	Maintenance Laptop	PC	6
5	Design, survey, Installation and Commissioning of a fully functional Fiber Network Management System for the entire network	Lot	1
6	Factory Acceptance Test (FAT) for officers	Activity	1
7	Training at manufacture's premises	Activity	1
8	On the job training during installation and commissioning	Activity	1

***NOTES: -**

1. All Tenderers must indicate the type, model (where applicable), dimensions and weight of the goods in their bid documents.
2. KPLC to cater for accommodation and air travel during FAT and Training
3. Bidder(s) to submit breakdown of prices of all respective items (Products & Services).

SECTION VI (a) SCHEDULE OF RATES AND PRICES

(TENDERER MUST INDICATE THE CURRENCY OF THE OFFER PRICE)

PRICE SCHEDULE FOR SUPPLY
FOR GOODS FROM ABROAD/OVERSEAS

No.	Description	Quantity	Country of origin	Unit price DDP VAT Exclusive	Unit price DDP VAT Inclusive	Total price DDP VAT inclusive
1	Supply of Fiber Network Management System (NMS) complete with all accessories, hardware, software and licenses for (Server, RTU(s), Switches, Cabinets etc.).	1				
2	Cost of Annual License if applicable					
3	Graphic Display as per specification	1				
4	Desktop Computer as per specification	3				
5	Maintenance Laptop	6				
6	Design, survey, Installation and Commissioning of a fully functional Fiber Network Management System for the entire network	1				
7	Factory Acceptance Test (FAT) for officers	1				
8	Training at manufacture's premises	1				
9	On the job training	1				

	during installation and commissioning					
--	--	--	--	--	--	--

FOR GOODS FROM THE EMPLOYER'S COUNTRY

No.	Description	Quantity	Country of origin	Unit price DDP VAT Exclusive	Unit price DDP VAT Inclusive	Total price DDP VAT inclusive
1	Supply of Fiber Network Management System (NMS) complete with all accessories, hardware, software and licenses for (Server, RTU(s), Switches, cabinets etc.)	1				
2	Cost of Annual License if applicable					
3	Graphic Display as per specification	1				
4	Desktop Computer as per specification	3				
5	Maintenance Laptop	6				
6	Design, survey, Installation and Commissioning of a fully functional Fiber Network Management System for the	1				

	entire network					
7	Factory Acceptance Test (FAT) for officers	1				
8	Training at manufacture's premises	1				
9	On the job training during installation and commissioning	1				

NOTE:-

1. *The offered unit price MUST be rounded to two decimal places. Where the Tenderer fails to round the offered unit price as required, then, the offered unit price shall be rounded down-wards to two decimal places and used for the purposes of this tender.*
2. *KPLC to cater for accommodation and air travel during FAT and Training*
3. *Bidder(s) to submit breakdown of prices of all respective items (Products & Services).*

SECTION VII - SUMMARY OF EVALUATION PROCESS

Evaluation of duly submitted tenders will be conducted along the following three main stages: -

7.1 Part I - Preliminary Evaluation Criteria Under Clause 3.35 of the ITT. These are mandatory requirements. This shall include confirmation of the following: -

7.1.1 Submission of Tender Security - Checking its validity, whether it is Original; whether it is issued as required in the tender document; whether it is strictly in the format required in accordance with the sample Tender Security Form(s).

7.1.2 Submission of Declaration Form(s) duly completed and signed.

7.1.3 Submission and considering Tender Form duly completed and signed.

7.1.4 Submission and considering the following: -

7.1.4.1 For Local Tenderers and subcontractors

- a) Company or Firm's Registration Certificate*
- b) PIN Certificate.*
- c) Valid Tax Compliance Certificate.*
- d) Names with full contact as well as physical addresses of previous customers of similar goods and reference letters from at least four (4) previous customers.*

7.1.4.2 For Foreign Tenderers and subcontractors

- a) Company or Firm's Registration Certificate*
- b) PIN Certificate or its equivalent in the country of bidder or a statement from the tax authorities in the Tenderer's country of origin indicating that such certificate or its equivalent is not issued.*
- c) Valid Tax Compliance Certificate or its equivalent in the country of bidder or a statement from the tax authorities in the Tenderer's country of origin indicating that such certificate or its equivalent is not issued.*
- d) Names with full contact as well as physical addresses of previous customers of similar goods and reference letters from at least Three (3) previous customers.*

- 7.1.5 *That the Tender is valid for the period required.*
- 7.1.6 *Site/Survey visit signed and stamped form by authorized staff (where applicable).*
- 7.1.7 *Valid certificate of registration by the relevant registration body as indicated in the tender.*
- 7.1.8 *Submission and considering the Confidential Business Questionnaire: -*
- a) *Is fully filled.*
 - b) *That details correspond to the related information in the bid.*
 - c) *That the Tenderer is not ineligible as per paragraph 3.3 of the ITT.*
- 7.1.9 *Submission and considering the Certificate of Confirmation of Directors and Shareholding if any one of the undertakings owns a significant interest in the other or has at least one director or one substantial shareholder in common as per paragraph 3.3 and 3.41 of the ITT.*
- 7.1.10 *Submission and considering the Implementation Plan*
- 7.1.11 *Confirming that no manufacturer has authorized more than one bid as per clause 3.2.1*
- 7.1.12 *Record of unsatisfactory or default in performance obligations in any contract shall be considered. This shall include any Tenderer with unresolved case(s) in its performance obligations for more than two (2) months in any contract.*
- 7.1.14 *Notwithstanding the above, considering any outstanding obligations/Supplier Performance Review Scheme (SPRS) where applicable and the performance capacity indicated by the Tenderer.*
- 7.1.15 *Tenderers confirmation that at least forty percent of their supplies is sourced from citizen contractors, where applicable.*
- 7.1.16 *Submission and checking that the Bill of Quantities is fully filled, priced, signed and stamped, where applicable.*

Tenderers will proceed to the Technical Stage only if they qualify in compliance with Part 1 above, Preliminary Evaluation under clause 7.

7.2 Part II - Technical Evaluation under clause 3.41 of the ITT. It will include the following stages: -

Part II (a) – These are mandatory requirements

Evaluation of the following Technical information against Tender Requirements and Specifications: -

7.2.1 Evaluation of the following technical information against Tender Requirements and Specifications: -

7.2.1.1 For goods manufactured outside Kenya, applicable relevant valid ISO 9001 certification

7.2.1.2 For goods manufactured in Kenya - valid KEBS Mark of Quality Certificate or KEBS Standardization Mark Certificate.

7.2.1.3 Type Test Certificates and their Reports or Test Certificates and their Reports from the designated bodies for full compliance with Tender Specifications

7.2.1.4 The accreditation certificate for the testing laboratory to ISO/ IEC 17025.

7.2.1.5 Manufacturer's Authorization

7.2.1.6 As contained in the following documents –

a) Manufacturer's Warranty

b) Catalogues and or Manufacturer's drawings

c) Schedule of Guaranteed Technical Particulars as per Technical Specifications.

7.2.2 Detailed Technical Evaluation

The Schedule of Mandatory Guaranteed Technical (GTP) shall be evaluated against Tender Specifications to confirm compliance of the goods and services to the specifications and evaluation of any deviations and exceptions declared by the Tenderer.

Tenderers will proceed to the next evaluation stage if they qualify in compliance with Parts II (a) above.

Part II (b) - Technical Evaluation under clause 3.20 of the ITT. It will include the following stages: The following will be scored.

NO.	EVALUATION CRITERIA	Maximum Marks
7.2.3	<i>Previous experience: Details of similar projects undertaken successfully within the <u>last 5 years</u> and evidenced by letters of reference from clients, completion certificates for the respective projects. (i) 5-years – 15 Marks, (ii) 3-Years - 10 Marks, (iii) 2 Years – 5 Marks</i>	15
7.2.4	<i>Qualified Key personnel as required under clause 3.20.2 in the tender relevant to the works who will actively be involved in the proposed project. Evidence of registration with relevant professional bodies. (Provide detailed recently signed CVs accompanied by relevant academic and professional certificates. Telephone contacts must be provided) (Bachelor’s Degree in related field plus Professional Registration – 20 Marks, Bachelor’s Degree only – 15 Marks)</i>	20
7.2.5	<i>Project Manager’s Experience – (i) 10 years and above 10 Marks, (ii) 5 years - 5 Marks</i>	10
7.2.6	<i>Optimal Design(s) and Solution Presentations: Diagrams & Clear Illustrations of the Solutions. The desired proposed solution optimal and uses least fiber capacity and number of RTUs for monitoring.</i>	30
7.2.7	<i>Equipment. Give a list and type of relevant equipment owned by the company evidenced by ownership documents. Where not owned by the company, provide documentary evidence of leased equipment as required under clause 3.20.2</i>	5
7.2.8	<i>Proposed completion period for the project accompanied by a proposed Implementation Plan with completion date (Gantt Chart)</i>	10
7.2.7	<i>Detailed review of documents required in the tender (e.g. warranties, sub-contractors details, references etc.)</i>	5
7.2.9	<i>Registration with CA, ERC, FOA, NCA or relevant authority for the respective Category/Class)</i>	5
	TOTAL	100

Note: Tenderers will proceed to the next evaluation stage if they score a minimum of **75%** in Parts II (b) above.

Part II (c) – Where applicable, Technical Evaluation under clause 3.22 of the ITT will include the following stages.

Table A – PITCH/PRESENTATION

<i>NO.</i>	<i>EVALUATION CRITERIA</i>	<i>Maximum Marks</i>

Table B – DEMONSTRATION AT SITE/REFERENCE SITE

<i>NO.</i>	<i>EVALUATION CRITERIA</i>	<i>Maximum Marks</i>

Note:

Tenderers will proceed to Financial Evaluation stage only if they score a minimum score of 75% in Parts II (c) above.

7.3 Part III – Financial Evaluation under clause 3.38 of the ITT.

Evaluation of the following Financial information against Tender Requirements and Specifications: -

NO.	EVALUATION CRITERIA
7.3.1	<i>a) Confirmation of the authenticity and sufficiency of the submitted Tender Security</i>
	<i>b) Confirmation of and considering schedule of rates and prices and/or priced Bill of Quantities duly completed and signed.</i>
	<i>c) Checking that the Tenderer has quoted prices based on all costs including insurances, duties, levies, Value Added Tax (V.A.T), Withholding Tax and other taxes payable and delivery to the premises of KPLC or designated site(s)</i>
	<i>d) Where applicable, Conducting a financial comparison, including conversion of tender currencies into one common currency</i>
	<i>e) Taking into account the cost of any deviation(s) from the tender requirements</i>
7.3.2	<p><i>Ascertaining the financial capability through Last Financial Year's audited financial statements issued within the last 18 months which Statements should conform to International Accounting Standards One (IAS 1) which includes the following: -</i></p> <p><i>a) Turnover in the Last Financial Year i.e. twelve months of at least 40% of the total tendered value.</i></p> <p><i>b) Checking and considering that the Tenderer's solvency ratios are acceptable to KPLC and meet the threshold of: -</i></p> <p><i>(i) Solvency ratio of Debt to Assets Ratio which should be at least 1:1</i></p> <p><i>Or</i></p> <p><i>(ii) for companies or firms that are registered or incorporated within the last one calendar year of the Date of the Tender Document, a spot cash balance of a minimum of 20% of the Tender Price. The same should be as evidenced in the certified copies of bank statements at least in ALL days of the month of the Date of the Tender Document.</i></p>
7.3.4	<i>Provide documentary evidence of liquid assets and/or credit facilities, net of other contractual commitments and exclusive of any advance payments</i>

	<i>which may be made under the contract.</i>
7.3.5	<i>Considering information submitted in the Confidential Business Questionnaire against other information in the bid including declared maximum value of business.</i>
	TOTAL

The Successful Tenderer shall be the one with the lowest evaluated price.

***NOTES: -**

1. For purposes of evaluation, the exchange rate to be used for currency conversion shall be the selling exchange rate prevailing on the date of tender closing provided by the Central Bank of Kenya. (Visit the Central Bank of Kenya website).
2. Total tender value means the Tenderer's total tender price inclusive of Value Added Tax (V.A.T) for the works it offers to provide.
3. For companies or firms that are registered or incorporated within the last one calendar year of the Date of the Tender Document, they should submit certified copies of bank statements covering a period of at least six months prior to the date of the tender document. The copies should be certified by the Bank issuing the statements. The certification should be original.
4. The spot balance of 20% required will be that which is seen in the certified bank statements at least in any day of the month of the Date of the Tender Document.

TABLE OF CLAUSES ON GENERAL CONDITIONS OF CONTRACT

Clause No.	Headings	Page No.
8.1	Definitions	..
8.2	Application	.
8.3	Country of Origin	..
8.4	Standards	.
8.5	Use of Contract Documents and Information	.
8.6	Patent Rights	.
8.7	Performance Security	..
8.8	Approval before Manufacture	.
8.9	Inspections and Tests	..
8.10	Pre ó Shipment Verification of Conformity	.
8.11	Consignment
8.12	Packaging and Labeling	.
8.13	Delivery and Documents for Goods on Delivered Duty Paid (DDP) Terms	
.8.14	Transportation	..
8.15	Liability and Insurance	..
8.16	Payment	..
8.17	Interest	.
8.18	Prices	..
8.19	Variation of Contract	.
8.20	Assignment	.
8.21	Sub-Contracts
8.22	Project Manager	..
8.23	Works	.
8.24	Safety at work sites	.
8.25	Discoveries	.
8.26	Access to site
8.27	Instructions	.
8.28	Dayworks	.
8.29	Early Warning	.
8.30	Defects	.
8.31	Completion and Taking Over	..
8.32	Retention/Defects Liability	.
8.33	Early Completion	.
8.34	Corrupt Gifts	.
8.35	Termination	..

8.36	Force Majeure	í í í í í í í í í í í í í í í í í í í ..
8.37	Liquidated Damages	í í í í í í í í í í í í í í í í í í í .
8.38	Warranty	í ..
8.39	Resolution of Disputes	í í í í í í í í í í í í í í í í í í í í
8.40	Language and Law	í í í í í í í í í í í í í í í í í í í í
8.41	Waiver	í ..

SECTION VIII – GENERAL CONDITIONS OF CONTRACT

The General Conditions of Contract *hereinafter referred abbreviated as the GCC* shall form part of the Conditions of Contract in accordance with the law and KPLC's guidelines, practices, procedures and working circumstances. The provisions in the GCC will apply unless an alternative solution or amendment is made under other parts of the Contract including the Special Conditions of Contract.

8.1 Definitions

In this contract, the following terms shall be interpreted as follows: -

- a) **“Day”** means calendar day and **“month”** means calendar month.
- b) **“Dayworks”** are work inputs subject to payment on a time basis for labour and the associated materials and plant.
- c) **“Certificate of Acceptance”** means the certificate issued by KPLC to the Contractor confirming that the Works have been completed as per the terms of the Contract.
- d) **“The Contract”** means the agreement entered into between KPLC and the Contractor, as recorded in the Contract Form signed by the parties, including all attachments and appendices thereto and all documents incorporated by reference therein.
- e) **“The Contract Price”** means the price payable to the Contractor under the contract for the full and proper performance of its contractual obligations.
- f) **“A Defect”** is any part of the Works not completed in accordance with the Contract.
- g) **“The Defects Liability Certificate”** is the certificate issued by the Project Manager upon correction of defects by the Contractor.
- h) **“The Defects Liability Period”** is the period specified in the Special Conditions of Contract when the Contractor is to remedy any defects in the Works.
- i) **“The Goods”** includes all of the equipment, machinery, and or other materials, which the Contractor is required to supply to KPLC under the contract and install and commission under the contract as the case may be.
- j) **“Party”** means KPLC or the Contractor or both as the context so requires.
- k) **“Project Manager”** is the employee of KPLC responsible for supervising the execution of the Works and administering the Contract.

- l) **“Site”** is the area where the Works under this Contract are to be carried out as specified in the Contract.
- m) **“The Contractor”** means the individual or firm supplying the goods and undertaking the Works under this Contract as the case may be or his/ her/ its permitted heir(s), personal representative(s), successor(s) or permitted assign(s) where the context so admits. For the avoidance of doubt this shall mean the successful Tenderer(s) pursuant to the tender.
- n) **“Works”** means the construction, repair, renovation or demolition of buildings, roads or other structures and includes the design, supply, installation, testing and commissioning of equipment and materials, site preparation and other incidental services where applicable.
- o) Wherever used in the contract, “delivery” shall be complete or be deemed to be complete, unless the circumstances indicate otherwise, when the goods have been inspected and tested in accordance with the Contract and where KPLC does not signify its approval to the Contractor, but retains the goods without giving notice of rejection, on the expiration of thirty (30) days from date of documented receipt by the duly authorized representative of KPLC, of the goods, at KPLC stores or other indicated site.

8.2 Application

These General Conditions shall apply to the extent that provisions of other parts of the contract do not supersede them.

8.3 Country of Origin

8.3.1 For purposes of this clause, “Origin” means the place where the goods were mined, grown, or produced.

8.3.2 The origin of Goods and Services is distinct from the nationality of the Contractor.

8.4 Standards

The Goods supplied under this contract shall conform to the standards mentioned in the Technical Specifications.

8.5 Use of Contract Documents and Information

8.5.1 The Contractor shall not, without KPLC’s prior written consent, disclose the contract, or any provision thereof or any specification, plan, drawing, pattern, sample, or information furnished by or on behalf of KPLC in connection therewith, to any person other than a person employed by the Contractor in the performance of the contract.

8.5.2 The Contractor shall not, without KPLC’s prior written consent, make use of any document or information enumerated in clause 8.5.1 above.

8.5.3 Any document, other than the contract itself, enumerated in clause 8.5.1 shall remain the property of KPLC and shall be returned (including all copies) to KPLC on

completion of the Contractor's performance under the contract if so required by KPLC.

8.6 Patent Rights

The Contractor shall indemnify KPLC against all third party claims of infringement of patent, trademark, or industrial design rights arising from use of the goods of any part thereof in KPLC's country.

8.7 Performance Security

8.7.1 Within fourteen (14) days of the date of the notification of contract award, the Contractor shall furnish to KPLC the Performance Security which shall be either one or a combination of the following:-

- a) an original Bank Guarantee that is strictly in the form and content as prescribed in the Performance Security Form (Bank Guarantee) in the Tender Document.
- b) Confirmed Standby Letters of Credit (LC). All costs, expenses and charges levied by all banks party to the LC including confirmation charges shall be prepaid/borne by the successful Tenderer. Certain mandatory conditions of the LC shall be as prescribed in the Performance Security Form (LC) in the Tender Document.

8.7.2 The Performance Security shall be issued by a commercial bank licensed by the Central Bank of Kenya. The bank must be located in Kenya.

8.7.3 The Performance Security shall be the sum of ten percent (10%) of the contract price. It shall be in the currency of the contract price.

8.7.4 Failure of the Contractor to furnish the Performance Security, the award shall be annulled and the Tender Security forfeited, in which event KPLC may notify the next lowest evaluated Tenderer that its Tender has been accepted.

8.7.5 The proceeds of the Performance Security shall be payable to KPLC as compensation for any loss resulting from the Contractor's failure to comply with its obligations in accordance with the contract without KPLC being required to demonstrate the loss it has suffered.

8.7.6 The Performance Security shall be valid for a minimum of sixty (60) days after satisfactory delivery, installation and commissioning for both Foreign and Local Contractors.

8.7.7 KPLC shall seek authentication of the Performance Security from the issuing bank. It is the responsibility of the Contractor to sensitize its issuing bank on the need to respond directly and expeditiously to queries from KPLC. The period for response shall not exceed five (5) days from the date of KPLC's query. Should there be no conclusive response by the Bank within this period, such Contractor's Performance Security may be deemed as invalid and the Contract nullified, unless information to

the contrary is received by KPLC two (2) days before the expiry of the Contractor's Tender Security.

- 8.7.8 Subject to the provisions of this contract, the Performance Security will be discharged by KPLC and returned to the Contractor not earlier than sixty (60) days following the date of completion of the Contractor's obligations under the contract, including any warranty obligations, under the contract.

8.8 Approval before Manufacture

- 8.8.1 All technical details and design drawings for the items to be supplied shall be submitted by the Contractor to KPLC for approval before manufacture.
- 8.8.2 Should the Contractor fail to observe this condition of approval before manufacture, KPLC may decline to accept the goods, or the Contractor shall either replace them or make alterations necessary, but in any case, KPLC shall incur no liability howsoever.

8.9 Inspection and Tests

- 8.9.1 KPLC or its representative shall have the right to inspect and/or to test the goods to confirm their conformity to the contract specifications. KPLC shall notify the Contractor in writing in a timely manner, of the identity of any representative(s) retained for these purposes.
- 8.9.2 Prior to the manufacture or production of the goods on order, KPLC reserves the right to inspect the manufacturing or production facility and the quality management system. The manufacturer or producer shall meet the cost of routine inspection while KPLC shall meet the cost of air travel to the nearest airport and accommodation of two of its nominated officers inspecting and witnessing tests.
- 8.9.3 It is the responsibility of the Contractor to confirm if this right is to be exercised. Such visit and or inspection shall in no way prejudice KPLC's rights and privileges.
- 8.9.4 Upon completion of manufacturing or production process, KPLC reserves the right to send two of its nominated officers to inspect the goods on order at the place of manufacture where inspection and acceptance tests as per tender specifications shall be carried out in their presence. Tests shall be done in accordance with the test standard(s) given in the Technical Specification of the goods on order.
- 8.9.5 The manufacturer or producer shall meet the cost of tests as per tender specifications while KPLC shall meet the cost of air travel to the nearest airport and accommodation of its two nominated officers inspecting and witnessing the tests.
- 8.9.6 The inspections and tests may be conducted on the premises of the Contractor or its subcontractor(s), at point of production, manufacture, delivery and or at the goods' final destination. If conducted on the premises of the Contractor or its subcontractor(s), all reasonable facilities and assistance, including access to drawings and production data, shall be furnished to the inspectors at no charge to KPLC. In all cases, the equipment used for tests must be validly calibrated by the national standards body and a copy (ies) of the calibration certificate(s) must be submitted with the test report(s).

- 8.9.7 Complete test report(s) for all the goods as per Tender Specifications shall be submitted to KPLC for approval before packaging and shipment. No material or goods shall be shipped or delivered without written approval from KPLC.
- 8.9.8 Should any inspected or tested goods fail to conform to the specifications, KPLC shall reject the goods, and the Contractor shall either replace the rejected goods or make alterations necessary to meet specification requirements free of cost to KPLC. The period for replacement or alterations together with delivery to KPLC shall be fourteen (14) days or as may otherwise be specified in the notice of rejection.
- 8.9.9 The Supplier shall collect the rejected goods within fourteen (14) days from the date of notification of rejection. If the rejected goods are not collected within this period, they shall attract storage and handling charges at prevailing market rates or as determined by KPLC without making any reference to the supplier pending the disposal of the goods by KPLC as guided by the Disposal of Uncollected Goods Act, Chapter 38 of the Laws of Kenya. .
- 8.9.10 Notwithstanding any previous inspection(s) and test(s) KPLC shall inspect and may test the goods upon arrival at the indicated site. Where KPLC inspects and rejects the goods after the goods arrival, KPLC shall claim from the Contractor the full cost of the goods including delivery charges to KPLC Stores or other indicated site and other incidental costs incurred in relation thereof.
- 8.9.11 KPLC's right to inspect, test and where necessary, reject the goods after their arrival shall in no way be limited or waived by reason of the goods having previously been inspected, tested and passed by KPLC or its representative(s) prior to the goods delivery.
- 8.9.12 For the avoidance of doubt, any acknowledgement by KPLC on the Contractor's or sub-contractor's document shall not be conclusive proof or evidence of satisfactory delivery without duly authorized approval by KPLC.
- 8.9.13 Nothing in clause 8.9 shall in any way release the Contractor from any warranty or other obligations under this Contract.

8.10 Pre-Shipment Verification of Conformity (PVoC)

- 8.10.1 All Contractors of imported goods and or products must obtain a Certificate of Conformity issued by an authorized KEBS appointed partner prior to shipment.
- 8.10.2 The Certificate is a mandatory customs clearance document in Kenya. KEBS has appointed, to perform the PVoC programme on their behalf depending on the country of supply origin. The cost of pre-shipment verification shall be borne by the Contractor.

8.11 Consignment

- 8.11.1 The terms shall be strictly on Delivered and Duty Paid (DDP) basis.
- 8.11.2 The Consignee shall be the supplier or supplier's agent whose responsibilities shall include payment of all Customs taxes, duties and levies, clearance of the goods, and

delivery to KPLC stores. For avoidance of doubt, this includes Value Added Tax (VAT), Railway Development Levy (RDL) and Import Duties.

8.12 Packaging and Labelling

- 8.12.1 The Contractor shall provide such packaging of the goods as is required to prevent their damage or deterioration during transit to their final destination, as indicated in the contract.
- 8.12.2 The method of packaging, labeling and marking shall comply strictly with such special requirements as shall be specified and attached to the Tender and particular Order.
- 8.12.3 The labelling, marking and documentation within and outside the packages shall comply strictly with such special requirements as shall be expressly provided for in the contract.
- 8.12.4 The goods shall be packed in good condition suitable for sea/air/road/rail dispatch. Hazard in transit to the final destination shall include rough handling and storage in tropical conditions.
- 8.12.5 The Contractor shall enclose a packing list in each package and all documents relating to the Order shall show the Stores Code Number detailed against the items.
- 8.12.6 The labeling on each package shall include the following;
 - (i) General description of the item(s)
 - (ii) KPLC Order No. í
 - (iii) Cautionary notes and handling instructions
 - (iv) Package number

8.13 Delivery and Documents for Goods on Delivered Duty Paid (DDP) Terms.

- 8.13.1 Delivery of the goods shall be made by the Supplier to the named place and in accordance with the terms specified by KPLC in its Schedule of Requirements.
- 8.13.2 The Supplier shall notify KPLC of the full details of the delivered goods by delivering together with the goods a full set of the following documents:-
 - a) *Supplier's invoice showing the goods description, quantity, unit price and total price*
 - b) *Delivery note for every consignment originating from the party contracted by KPLC. The Delivery Note should be serialized, dated and contain the number of the Official Purchase Order*
 - c) *Manufacturer's warranty certificate*
 - d) *Packing list identifying contents of each package which list should include casing number, full description of the items and the quantities in each package.*
- 8.13.3 It is the responsibility of the Supplier to ensure that the delivery documents are received by KPLC at the designated delivery point at the time of delivery.

- 8.13.4 Any late or non-submission of the delivery documents shall be treated as part of non-performance on the part of the Supplier and KPLC shall be entitled to call up the Performance Security.
- 8.13.5 The Supplier should notify KPLC in writing of its intention to deliver goods fourteen (14) days prior to delivery, and a further confirmation two (2) working days before actual delivery to the designated delivery point.

8.14 Transportation

- 8.14.1 The Supplier shall be required to meet all transport expenses until delivery.

8.15 Liability and Insurance

- 8.15.1 The goods supplied under the contract shall be fully insured by the Contractor against loss or damage incidental to manufacture, production or acquisition, transportation, storage and delivery in the manner specified in this Contract (Delivery Duty Paid terms).
- 8.15.2 The Contractor shall be responsible for and keep in force current appropriate insurance covers for its property and persons engaged in the performance of Works under the contract.
- 8.15.2 The Contractor shall (except in respect to losses, injuries or damage resulting from any act or neglect of KPLC) indemnify and keep indemnified KPLC against all losses and claims for injuries or damage to any person or property whatsoever which may arise out of or in consequence of the contract and against all claims, demands, proceedings, damages, costs, charges, and expenses whatsoever in respect thereof or in relation thereto.

8.16 Payment

- 8.16.1 Payments shall be made promptly by KPLC and shall not be less than thirty (30) days from delivery and submission of invoice together with other required and related documents or as otherwise prescribed in the contract.
- 8.16.2 Payment shall primarily be through KPLC's cheque or Real Time Gross Settlement (RTGS) or telegraphic transfer. Where applicable, a copy of a valid Performance Security, stamped, certified as authentic by KPLC, shall form part of the documents to be presented to KPLC before any payment is made. The terms shall be strictly on Delivered and Duty Paid (DDP) basis.
- 8.16.3 Contractors who request for a Letter of Credit (*hereinafter abbreviated as LC*)
 - a) *Shall meet all the LC costs. Indicative costs levied by the banks include opening charges (0.25% per quarter), confirmation charges (0.25% flat), settlement (0.25% flat), acceptance charges (0.25% flat) and any amendment charges.*

- b) *Any extension and or amendment charges and any other costs that may result from the Contractor's delays, requests, mistakes or occasioned howsoever by the Contractor shall be to the Beneficiary's account.*
- c) *The maximum number of extensions and amendments shall be limited to two (2).*
- d) *Should the Contractor require a confirmed LC, then all confirmation and any other related charges levied by both the Contractor's and KPLC's bank shall be to the Beneficiary's account.*
- e) *The LC shall be opened only for the specific Order within the validity period of the contract.*
- f) *LCs shall be partial for partial performance or full for whole performance as per the contract.*
- g) *The Contractor shall be required to submit a proforma invoice for each lot for use in the placement of order and opening of the LC. The proforma invoice shall be on total DDP basis.*
- h) *A copy of the Performance Security, stamped and certified as authentic by KPLC, whose expiry date should not be less than sixty (60) days from the LC expiry date, shall form part of the documents to be presented to the Bank before any payment is effected.*

8.16.4 KPLC shall have the sole discretion to accept or decline any Contractor's payment request through Letters of Credit without giving any reason for such decline.

8.17 Interest

8.17.1 Interest payment by KPLC is inapplicable in the contract.

8.18 Prices

8.18.1 Subject to clause 7.18.2 herein-below, prices charged by the Contractor for goods delivered and services performed under the contract shall, be fixed for the period of the contract with no variations.

8.18.2 A price that is derived by a pre-disclosed incorporation or usage of an internationally accepted standard formula shall not be deemed to be a price variation within the meaning of this clause.

8.19 Variation of Contract

KPLC and the Contractor may vary the contract only in accordance with the following: -

- a) *the quantity variation for goods shall not exceed ten percent (10%) of the original contract quantity.*
- b) *the quantity variation for works does not exceed fifteen per cent (15%) of the original quantity.*

- c) *the cumulative value of all contract variation shall not exceed twenty five per cent (25%) of the original contract price.*
- d) *the quantity variation must be executed within the period of the contract.*

8.20 Assignment

8.20.1 The Contractor shall not assign in whole or in part its obligations to perform under this contract, except with KPLC's prior written consent.

8.21 Subcontracts

8.21.1 The Contractor shall notify KPLC in writing of all subcontracts awards under this contract if not already specified in the tender. Such notification, in the original tender or obligation under the Contract shall not relieve the Contractor from any liability or obligation under the Contract.

8.21.2 In the event that an award is given and the Contract is sub contracted, the responsibility and onus over the contract shall rest on the Contractor who was awarded.

8.22 Project Manager

8.22.1 KPLC shall appoint a Project Manager who shall be an employee of KPLC and who will be responsible for supervising the execution of the Works. The names and contacts of the person appointed as the Project Manager shall be communicated to the Contractor once such appointment is made.

8.22.2 Except where otherwise specifically stated, the Project Manager will decide contractual matters between KPLC and the Contractor.

8.22.3 The Project Manager may delegate any of his duties and responsibilities to another KPLC employee and thereafter notify the Contractor of the person to whom such duties are delegated.

8.23 Works

8.23.1 The Contractor shall perform the Works in accordance with the specifications set out in the Contract.

8.24 Safety at Work Sites

8.24.1 The Contractor shall be responsible for the safety of all activities on the sites where Works are performed.

8.25 Discoveries

8.25.1 Anything of historical or other interest or of significant value unexpectedly discovered on site where the Works are being carried out shall be the property of

KPLC. The Contractor shall notify the Project Manager of such discoveries and carry out the Project Manager's instructions for dealing with them.

8.26 Access to Site (s)

8.26.1 The Contractor shall allow the Project Manager and any other person authorised by the Project Manager, access to the site (s) where Works are carried out and to any place where work in connection with the contract is being carried out or is intended to be carried out.

8.27 Instructions

8.27.1 The Contractor shall carry out all instructions of the Project Manager which are in accordance with the Contract.

8.28 Dayworks

8.28.1 If applicable, the Dayworks rates in the Contractor's tender shall be used for small additional amounts of work only when the Project Manager has given written instructions in advance for additional work to be paid for in that way.

8.28.2 All work to be paid for as Dayworks shall be recorded by the Contractor on Forms approved by the Project Manager. Each completed form shall be verified and signed by the Project Manager within two days of the work being done.

8.28.3 The Contractor shall be paid for Dayworks subject to obtaining signed Dayworks forms.

8.29 Early Warning

8.29.1 The Contractor shall warn the Project Manager at the earliest opportunity of specific likely future events or circumstances that may adversely affect the quality of the Works, increase the contract price or delay the execution of the Works.

The Project Manager may require the Contractor to provide an estimate of the expected effect of the future event or circumstance on the Contract Price and completion date. The estimate shall be provided by the Contractor as soon as reasonably possible.

8.29.2 The Contractor shall cooperate with the Project Manager in making and considering proposals on how the effect of such an event or circumstance can be avoided or reduced by anyone involved in the Works and in carrying out any resulting instructions of the Project Manager.

8.30 Defects

- 8.30.1 The Project Manager shall inspect the Contractor's work and notify the Contractor of any defects that are found. Such inspection shall not affect the Contractor's responsibilities. The Project Manager may instruct the Contractor to search for a defect and to uncover and test any Works that the Project Manager considers may have a defect. Should the defect be found, the cost of uncovering and making good shall be borne by the Contractor.
- 8.30.2 The Project Manager shall give notice to the Contractor of any defects before the end of the Defects Liability Period which begins after issuance of the Certificate of Acceptance by KPLC to the Contractor. The Defects Liability Period shall be extended for as long as defects remain to be corrected.
- 8.30.3 When notice of a defect is given; the Contractor shall correct the notified defect within the length of time specified by the Project Manager's notice. If the Contractor has not corrected a defect within the time specified in the Project Manager's notice, the Project Manager will assess the cost of having the defect corrected by other parties and such cost shall be treated as a variation and be deducted from the Contract Price.
- 8.30.4 The Project Manager shall issue the Contractor with a Defects Liability Certificate after the defects are corrected.

8.31 Completion and taking over

- 8.31.1 Upon assessment by the Project Manager that the Works are complete, KPLC shall issue the Contractor with a Certificate of Acceptance.

8.32 Retention/Defects Liability

- 8.32.1 KPLC shall retain 10% of the Contract Price for the duration of the Defects Liability Period after issuing the Certificate of Acceptance for the whole of the Works.

8.33 Early Completion

- 8.33.1 No bonus for early completion of the Works shall be paid to the Contractor by the Employer.

8.34 Corrupt gifts

- 8.34.1 The Contractor shall not offer or give or agree to give to any person in the service of the KPLC any gift or consideration of any kind as an inducement or reward for doing or forbearing to do or for having done or forborne to do any act in relation to the obtaining or execution of this or any other Contract for KPLC for showing or forbearing to show favour or disfavour to any person in relation to this or any other contract with KPLC.
- 8.34.2 Any breach of this Condition by the Contractor or by anyone employed by him or acting on his behalf (whether with or without the knowledge of the Contractor) shall

be an offence under the provisions of the Public Procurement and Disposal Regulations 2005 and the regulations made thereunder.

8.35 Termination

8.35.1 KPLC may, without prejudice to any other remedy for breach of contract, by written notice sent to the Contractor, terminate this contract in whole or in part due to any of the following: -

- a) *if the Contractor fails to perform any obligation(s) under the contract.*
- b) *if the Contractor in the judgment of KPLC has engaged in corrupt or fraudulent practices in competing for or in executing the contract.*
- c) *by an act of force majeure.*
- d) *if the Contractor becomes insolvent or bankrupt*
- e) *if the Contractor has a receiving order issued against it, compounds with its creditors, or an order is made for its winding up (except for the purposes of its amalgamation or reconstruction), or a receiver is appointed over its or any part of its undertaking or assets, or if the Contractor suffers any other analogous action in consequence of debt.*
- f) *the Contractor stops work for 30 days when no stoppage of work is shown on the current program and the stoppage has not been authorised by the Project Manager;*
- g) *the Project Manager gives notice that failure to correct a particular defect which is a fundamental breach of Contract and the Contractor fails to correct it within a reasonable period of time determined by the Project Manager;*
- h) *if the Contractor abandons or repudiates the Contract*

8.35.2 KPLC may by written notice sent to the Contractor, terminate the Contract in whole or in part, at any time for its convenience. The notice of termination shall specify that the termination is for KPLC's convenience, the extent to which performance, by the Contractor, of the Contract, is terminated and the date on which such termination becomes effective.

8.35.3 For the remaining part of the Contract after termination for convenience, KPLC may pay to the Contractor an agreed amount for partially completed satisfactory performance of the Contract.

8.35.4 In the event that KPLC terminates the Contract in whole or in part, it may procure, upon such terms and in such manner as it deems appropriate, goods similar to those undelivered or not rendered, and the Contractor shall be liable to KPLC for any excess costs for such similar goods and or any other loss PROVIDED that the Contractor shall not be so liable where the termination is for convenience of KPLC.

8.35.5 The Parties may terminate the Contract by reason of an act of *force majeure* as provided for in the contract.

8.35.6 The Contract may automatically terminate by reason of an act of *force majeure* as provided for in the Contract.

8.35.7 If the Contract is terminated, the Contractor shall stop work immediately, make the Site safe and secure, and leave the Site as soon as reasonably possible. The Project Manager shall immediately thereafter arrange for a meeting for the purpose of taking record of the Works executed and materials, goods, equipment and temporary buildings on Site.

8.36 Force Majeure

8.36.1 *Force majeure* means any circumstances beyond the control of the parties, including but not limited to: -

- a) *war and other hostilities (whether war be declared or not), invasion, act of foreign enemies, mobilization, requisition or embargo;*
- b) *ionizing radiation or contamination by radio-activity from any nuclear fuel or from any nuclear waste from the combustion of nuclear fuel, radioactive toxic explosives or other hazardous properties of any explosive nuclear assembly or nuclear components thereof;*
- c) *rebellion, revolution, insurrection, military or usurped power and civil war;*
- d) *riot, commotion or disorder except where solely restricted to employees servants or agents of the parties;*
- e) *un-navigable storm or tempest at sea.*

8.36.2 Notwithstanding the provisions of the contract, neither party shall be considered to be in default or in breach of its obligations under the contract to the extent that performance of such obligations is prevented by any circumstances of *force majeure* which arise after the Contract is entered into by the parties.

8.36.3 If either party considers that any circumstances of *force majeure* are occurring or have occurred which may affect performance of its obligations it shall promptly notify the other party and provide reasonable proof of such circumstances.

8.36.4 Upon the occurrence of any circumstances of *force majeure*, the Contractor shall endeavour to continue to perform its obligations under the contract so far as is reasonably practicable. The Contractor shall notify KPLC of the steps it proposes to take including any reasonable alternative means for performance, which is not prevented by *force majeure*. The Contractor shall not take any such steps unless directed so to do by KPLC.

8.36.5 If the Contractor incurs additional costs in complying with KPLC's directions under sub clause 8.37.4, then notwithstanding the provisions of the Contract, the amount thereof shall be agreed upon with KPLC and added to the contract price.

8.36.6 If circumstances of *force majeure* have occurred and shall continue for a period of twenty-one (21) days then, notwithstanding that the Contractor may by reason thereof have been granted an extension of time for performance of the contract, either party shall be entitled to serve upon the other seven (7) days' notice to terminate the Contract. If at the expiry of the period of twenty-eight (28) days, *force majeure* shall still continue, the contract shall terminate.

8.37 Liquidated Damages

Notwithstanding and without prejudice to any other provisions of the Contract, if the Contractor fails to deliver any or all of the goods or complete the Works within the period specified in the contract, KPLC shall, without prejudice to its other remedies under the contract, deduct from the contract prices, liquidated damages sum equivalent to 0.5% of the delivered or shipment price (whichever is applicable) per day of delay of the delayed items up to a maximum of ten percent (10%) of the delivered price of the delayed goods.

8.38 Warranty

- 8.38.1 The Contractor warrants that the Goods supplied under the contract are new, unused, of the most recent or current specification and incorporate all recent improvements in design and materials unless provided otherwise in the contract. The Contractor further warrants that the goods supplied under this contract shall have no defect arising from manufacture, materials or workmanship or from any act or omission of the Contractor that may develop under normal use of the supplied goods under the conditions obtaining in Kenya.
- 8.38.2 This warranty will remain valid for the period indicated in the special conditions of contract after the goods, or any portion thereof as the case may be, have been delivered, installed and commissioned at the final destination indicated in the contract.
- 8.38.3 KPLC shall promptly notify the Contractor in writing of any claims arising under this warranty.
- 8.38.4 Upon receipt of such a notice, the Contractor shall, with all reasonable speed, replace the defective goods without cost to KPLC.
- 8.38.5 If the Contractor having been notified fails to remedy the defect(s) within a reasonable period, KPLC may proceed to take such remedial action as may be necessary, at the Contractor's risk and expense and without prejudice to any other rights which KPLC may have against the Contractor under the contract.

8.39 Resolution of Disputes

- 8.39.1 KPLC and the Contractor may make every effort to resolve amicably by direct informal negotiation any disagreement or dispute arising between them under or in connection with the contract.
- 8.39.2 If, after thirty (30) days from the commencement of such informal negotiations both parties have been unable to resolve amicably a contract dispute, either party may resort to resolution before a recognized local forum for the resolution of disputes.

8.40 Language and Law

The language of the contract and the law governing the contract shall be the English language and the laws of Kenya respectively unless otherwise stated.

8.41 Waiver

Any omission or failure by KPLC to exercise any of its rights or enforce any of the penalties arising from the obligations imposed on the Contractor shall in no way, manner or otherwise howsoever, alter, amend, prejudice, vary, waive or be deemed to alter, amend, prejudice, vary, waive or otherwise whatsoever any of KPLC's powers and rights as expressly provided in and as regards this contract.

SECTION IX – SPECIAL CONDITIONS OF CONTRACT

The Special Conditions of Contract *hereinafter abbreviated as SCC* shall form part of the Conditions of Contract. They are made in accordance with the law and KPLC's guidelines, practices, procedures and working circumstances. They shall amend, add to and vary the GCC. The clauses in this section need not therefore, be completed but must be completed by KPLC if any changes to the GCC provisions are deemed necessary. Whenever there is a conflict between the GCC and SCC, the provisions of the SCC shall prevail over those in the GCC.

No.	GCC Reference Clause	Particulars of SCC
	8.14 Terms of Payment	<i>The credit period shall be thirty (30) days from satisfactory delivery and submission of invoice together with other required and related documents.</i>
	8.20 Project Manger	<i>The Project Manager appointed by KPLC: Name: Address: Telephone:</i>
	8.36 Warranty Period	<i>(Three (3) Years</i>
	8.29 Defects Liability Period	<i>1 year after commissioning</i>

SECTION X - TECHNICAL SPECIFICATIONS

1. PARTICULAR TECHNICAL SPECIFICATIONS

1. GENERAL INFORMATION

1.1 General Requirements

The Contractor shall bear full responsibility that he has understood the operation of the system.

No deviations shall be made from this specification and standards unless waived or modified in writing by the Employer. The Contractor shall obtain from its sub-contractor a statement as to compliance with this specification without exception and/or if there are any exceptions, these shall be described in detail and included in the Contractor's Tender. The Contractor shall add a statement that no other exceptions are taken to this specification.

Works to be provided by the Contractor

The Contractor shall provide the Services as described in the scope of the contract

Works to be provided by the Employer

The Employer shall provide access to all the sites and equipment covered by the contract.

1.2 Codes and Standards

General

The service delivered shall be in accordance with, but not limited to, the latest issues of the applicable standards in effect at time of signing the contract unless otherwise stated in this specification.

The instruments and all equipment used shall be manufactured, calibrated and tested to latest editions of appropriate standards and meet the requirements of the following bodies:

- Federal Communications Commission (FCC)
- European Standards Commission
- International Telecommunications Union (ITU)
- International Electrotechnical Commission (IEC)
- Union Internationale des Chemins de Fer (UIC)

- International Radio Consultative Committee (CCIR)
- Institution of Electrical Engineers of Great Britain (IEE) and any Kenya amendments thereto.
- Communications Authority of Kenya (CAK)
- Kenya Bureau of Standards (KEBS)
- National Environmental Management Authority (NEMA)
- Kenya Power and Lighting Company (KPLC)
- Bye-Laws of the Local Authority(s)
- Other regulations applicable to the installations in Kenya
- Fiber Optic Association (FOA)
- Energy Regulatory Commission (ERC)
- Communication Authority of Kenya (CA)

These codes and standards set forth the minimum requirements which may be exceeded by the Contractor if, in the Contractor's judgement and Employer's acceptance, superior or more economic.

In addition to the applicable standards, the Contractor shall comply with all applicable international, national and local laws, codes, regulations, statutes and ordinances. The Contractor shall comply with the standards applicable in the country of origin for all materials as if the installation was being done in that country.

The materials and services furnished shall comply with and not prevent the Employer's compliance with all applicable standards of the local codes.

In the event of any apparent conflict among standards or these specifications, the Contractor shall refer the conflict to the Employer for written resolution.

address for the service of notices.

Abbreviations

This Technical Report uses the following abbreviations

SCADA/EMS	Supervisory Control and Data Acquisition / Element Management System
OPGW	Optical ground wire fiber cable
ADSS	All dielectric self-supporting fiber cable
NMS	Optical Management System
OPEX	Operation expenditure
MTTR	Mean Time to Restore
FTTH/x	Fiber to the Home
GIS	Global Information System
RTU	Remote Test Unit
KPLC	Kenya Power and Lighting Company
OTDR	Optical Time Domain Reflectometer
NOC	Network Operation Center
NCC	National Control Centre
ORL	Optical Return Loss
PON	Passive Optical Networks
SNMP	Simple Network Management Protocol
VPN	Virtual Private Network
GUI	Graphical User Interface
IP	Internet Protocol
SMS	Short Message Services
OS	Operating System
OE	
GB	Giga Bit
TB	Tera-Bit
PCI	Peripheral Component Interface
SATA	Serial Advanced Technology Attachment
DVD-RW	Digital Versatile Disk ó Read Write
USB	Universal Serial Bus
DIMM	Dual-In-line Memory Module
RAID	Redundant Array of Independent Disks
SQL	Structured Query Language
MYSQL	MY- Structured Query Language
TOD	Test-On-Demand (TOD)
RTU	Remote Test Unit
EMI/ESD	Electromagnetic Interference / Electrostatic Discharge
CE	European Conformity
SSD	Solid State Disk
IEC	International Electrotechnical Commission
UPC	Ultra-Polish Connector
GSM	Global System for Mobile
WiMAX	Worldwide Interoperability for Microwave Access

VGA	Video Graphics Adapter/Array
DVI	Digital Visual Interface
HDMI	High-Definition Multimedia Interface
RAM	Random Access Memory
DDR	Double Data-Rate
LED	Light Emitting Diode
Wi-Fi	Wireless Fidelity
Hz	Hertz
PC	Personal Computer
DVI-D	Digital Visual Interface ó Digital
BNC	Bayonet NeillóConcelman
DDC/CI	Display Data Channel/Command Interface
POE	Power Over Ethernet
SFP	Small Form-factor Pluggable
RU	Rack Unit
SLA	Service Level Agreement
PDF	Portable Document Format

2. DETAILED TECHNICAL SPECIFICATIONS

3.1 Background

KPLC has developed a countrywide optical fiber network used for the Supervisory Control and Data Acquisition / Element Management System (SCADA/EMS) in monitoring the power system and the company's corporate data network. The fiber optic network has grown from approximately **1,200km** in 2010 to over **4,000km** in 2016 with ongoing projects to further extend the network coverage.

The KPLC optical fiber network consists of:

- i. Optical ground wire fiber cable (OPGW) approximately 1800km.
- ii. All dielectric self-supporting fiber cable (ADSS) approximately 2200km

The lease services offered to the Telecom Service Providers by KPLC require service availability at 99.99% as per the Service Level Agreement (SLA). This requires an optical management system (NMS) to enhance network availability through;

- i. Early fault detection
- ii. Online monitoring and localization of faults
- iii. Reduction of the Operation expenditure (OPEX) by reducing the resource mobilization costs and the mean time to restore (MTTR).
- iv. Automatic network database management.

The desired NMS solution shall monitor the dark fiber links on the backbone OPGW, the ADSS county and Metro fiber networks respectively and the upcoming Fiber to the Home FTTH/x passive optical Networks PONs.

3.1.1 Scope

The proposed solution shall cover survey, design, installation and commissioning of the optical network management system for the entire fiber optic network comprising the backbone OPGW, county and Metro fiber ADSS and upcoming FTTH / x (PONS). The solution shall provide for monitoring at three (3) locations namely; Stima Mall NOC, KPI and at NCC-Juja. During the survey, bidder(s) shall identify suitable locations and cabling routes for all services envisaged.

3.2 Solution Key Attributes

The NMS shall be a fully functional and integrated system. It will comprise of the Network Server and database (GIS, Oracle, Inventory) and the remote test unit (RTU) to carry out remote fiber test(s) and fault localization using a single fiber core to be provided by Kenya Power and Lighting Company (KPLC). The RTU(s) shall be optimally located at existing KPLC substations to ensure maximum monitoring of the network. Deviations in the fiber cable will be compared against a standard reference measurement taken through an Optical Time Domain Reflectometer (OTDR) and stored in a database. A fault alarm notification shall be generated and communicated to the Network Operation Center (NOC) where corresponding trouble ticket (s) will be raised with unique reference(s).

The RTUs shall be capable of comprehensive monitoring and detection of fiber cuts, attenuation, reflectance change, optical return loss (ORL) change, external alarm integration for environmental monitoring and access, fiber extension among others. The RTU(s) to be located at strategic Kenya Power Substations will be able to utilize optical

switches hence monitor each outgoing fiber link from the substation using dedicated single fiber. In addition to the foregoing, the RTU(s) shall support *LAN*, *WAN* and wireless connectivity access for redundancy option(s). KPLC will provide the required - 48 dc supply at the substations however bidders are expected to confirm suitability. The NMS will be located at 7th floor Stima Mall Parklands where there exists a fiber connectivity to the backbone network. There shall be two more sites equipped with monitoring terminals namely at KPI-Ruaraka and NCC-Juja there exists fiber optic connectivity to the backbone. Existing KPLC servers will be used for Server and Database redundancy. The comprehensive solution shall monitor backbone fiber, Metro Networks and Passive Optical Networks (PONS).

3.3 Features of the NMS

The NMS shall be capable of the following functionality and features:

- i. Fault Detection, reporting and isolation
- ii. Early detection to prevent breakdowns
- iii. Security features enabling prevention, Detection and reaction to any breach.
- iv. Scalable for future growth (*component and link addition*).
- v. Remote test capability for both Point to Point and Point to Multi Point.
- vi. Web support via SNMP, XML etc.
- vii. Scalable architecture (domains - Areas) with capability to view and monitor up to the PON level.
- viii. Provide network inventory and update.

3.4 NMS

3.4.1 Server Hardware

The NMS Application and Database Server shall run on a single high performance hardware platform featuring 64-bit operating system, a fast multicore processor and sufficient memory and storage space to run the NMS efficiently. The server shall also feature a fast network adaptor.

The Server shall be installed at the existing KPLC NOC located at Stima Mall Building in Parklands, Nairobi.

3.4.2 Operating System

The server shall feature 64-bit Windows Server 2012 or later and shall feature all the utilities and tools needed to effectively run the NMS.

3.4.3 Application Software

The application software platform shall provide for:

- i. Fully web access compatible via SNMP
- ii. Centralized server architecture
- iii. Auto detection of; RTU(s), client software upgrades, data analytics and reporting.
- iv. Automated alarm management, data analysis, reporting and distribution.
- v. Integration for use with GIS and Mapping software for precise fault location

3.4.4 Software and User Licenses

The supplier shall specify clearly the applicable licenses and any costs associated if any regarding number of users/ clients, software updates and firmware updates. The recurrent costs, duration and renewals of such licenses shall clearly be indicated

where applicable. It is preferred that a minimum of three (3) users shall be able to access the system simultaneously.

3.4.5 Database

KPLC has an existing GIS database. It is expected that the solution provided shall import data from the existing GIS System.

3.4.6 Auto-Discovery and Provisioning Function

It is desired that the system builds up inventory comprising all elements configurable, perform auto discovery of RTU(s), new links and builds a knowledge base of the network including changes made without any additional user intervention.

3.4.7 Backup and Restore

The solution shall provide for back-up and restore for Application and Database configurations in real time. There shall be an auto switch over to the backup configuration in case of breakdown to the primary option (s) or change of media. There shall be a restore option in case of accidental changes during maintenance to the previous configuration.

3.4.8 Database Clean-Up

It shall be possible to clear or remove data such as alarm logs, reports etc. that have exceeded an age limit defined by the user. It shall be possible to have different clean-up schedules for different classes of users.

3.4.9 System Administration

The system shall provide for set up of domains and user groups, manage user privileges and log user activity. The system shall also provide for secure access control to the system with effective password management. Access to the system shall be through log on password via web based application. Access rights shall be provided for web access, domain(s), user groups and specific functions.

Options for offline access to view or edit data shall be specified.

3.4.10 Alarm Monitoring and Management

Deviation(s) from the reference trace shall be captured and alarms raised based on severity on availability of the link. The system shall be capable of detecting faults and isolation, classification of alarms, alarm notification, alarm display configuration and clean-up of database on user specified period. The system shall be capable of both performing real-time network monitoring and development of a historical database. The system shall reference faults to nearest landmark, measuring optical distance to fault and establish fault location details (geographical positioning system GPS).

3.4.11 Performance Reporting and Documentation

The system shall provide for a live database in which performance data is analyzed with respect to set threshold as per applicable service availability levels. Items to be captured and reported shall include:

- i. Link alarms based on severity of incident
- ii. Incident Resolution time
- iii. Track quality of service (QoS)
- iv. Service Level Agreement (SLA) performance per link
- v. Management of equipment and environmental alarms respectively such temperature, humidity, access control, power failure etc.

- vi. Short term and long term network performance reports.
- vii. Inventory report(s): Routes, Cables, Fibers, Splices, Loops, Splitters, Central Offices, Hubs, Equipment Details, Ports and Nodes.

3.4.12 Scalability

The system shall provide for introduction of additional nodes at all levels across the entire network.

3.4.13 GIS and Mapping Software Integration

The system shall provide for integration with GIS and mapping software for accurate fault localization and visualization of the landmarks at fault location. This will enable support teams to quickly find the locations and hence save time.

3.5 Client Stations

A minimum of 3 (three) client stations shall be located at strategic KPLC Network Operation center and be capable of:

- i. IP connectivity to central server
- ii. Alarm management at each node
- iii. Remote access via VPN
- iv. Web access
- v. Information display on both primary and secondary display units

3.6 Graphical User Interface (GUI)

The GUI shall be easy to use and accessible from various terminals ranging from large screen displays, desktop terminals and mobile phones (smart). The display shall provide information such as operating conditions, link status, port status and fiber condition and geographic location of faults and any nearby landmarks. Real-time environmental data shall also be displayed in web view.

3.7 Remote Test Unit (RTU)

The RTUs shall be located at strategic KPLC substations on the backbone fiber route(s) to monitor as much of the network as possible. It is expected that the solution shall not comprise more than **15** RTUs. Each RTU node shall be supplied with a standard 19inch - 42U Telecom cabinet/rack per site. The RTUs shall have the following attributes:

- i. Mechanical Design: mountable in a standard 19-inch rack.
- ii. Replaceable/Plug-in OTDR module with ease of installation. This shall be used for remote testing and continual assessment of dark fiber cable.
- iii. Optical Switch module with various scalable options for various port numbers as per application.
- iv. Remote access and remote software upgrade.
- v. Inbuilt LAN & WAN switching capabilities.
- vi. IP support for both IPv4 and IPv6.
- vii. Wireless connectivity Interface module. Provide for back up connectivity via wireless interface or other third party network
- viii. Local Ethernet connectivity
- ix. Scalability - the unit shall be scalable for live fiber monitoring and PON networks.
- x. Alarm notification, recording and reporting via email and SMS

Below are the key transmission substations existing on the fiber backbone network. The substations have been selected due to other internal considerations like fiber and power availability, manned operations, security among others making them suitable locations for RTUs. Appendix 2 of the fiber network has been provided to guide on the selection of which substations to use for best design to monitor the whole network. It is desirable to use the least number of RTU sites in the design.

Table 1: KPLC Substations on the Backbone OPGW Fiber Network.

	KPLC OPGW SUBSTATIONS	Rating (KV)	- 48 DC Power Supply
1	Makande	33/11	Available
2	Kipevu HT	132/33	Available
3	Malindi ó Kakuyuni - KETRACO	220/33	Available
4	Garsen - KETRACO	220/33	Available
5	Lamu (Hindi) - KETRACO	220/33	Available
6	Rabai RCC	220/132/33	Available
7	Voi 132	132/33	Available
8	Kiboko	132/33	Available
9	Juja Road	132/66	Available
10	Dandora	220/132	Available
11	Nairobi North	220/66	Available
12	Embakasi	220/66/11	Available
13	Naivasha	132/33	Available
14	Lanet	132/33	Available
15	Makutano	132/33	Available
16	Lessos	220/132/33	Available
17	Rivatex	132/33	Available
18	Muhoroni	132/33	Available
19	Chemosit	132/33	Available
20	Kisii	132/33	Available
21	Musaga	132/33	Available
22	Tower 40	132	Not Available
23	Mumias	132/33	Available
24	Rangala - KETRACO	132/33	Available
25	Kamburu	132/220	Available
26	Meru	132/33	Available
27	Kiganjo	132/33	Available
28	Nanyuki	132/33	Available
30	Isiolo - KETRACO	132/33	Available
31	Mangu - KETRACO	132/33	Available

3.8 Network Architecture

The architecture should be scalable and provide for growth and network changes. The RTUs should be capable of stand-alone operation. KPLC fiber network is growing rapidly hence need for adaptation, upgrades and capacity. The current network diagram is attached at Appendix 2

3.9 Management of Service Level Agreement

The system shall be capable to monitor, analyze and display both the network performance and availability functions.

4.0 Network Monitoring

The system shall have network monitoring at three (3) separate locations. These shall be the main center NOC monitoring at Stima Mall, monitoring at KPI and NCC ó Juja respectively.

4. GUARRANTEED TECHNICAL PARTICULARS

Table 2: Table of Minimum Requirements for the NMS

1	NMS SERVER	
NMS SERVER ó 2U RACK	Make:	
	Model:	
	Country of Manufacture:	
	MINIMUM REQUIREMENTS	BIDDERS OFFER
	64-bit Processor, 3.4 GHz, 16 Core Server with Windows 2012 R2 Server OS	
	Memory, Standard:16GB RAM	
	Storage capacity: 1-TB	
	Expansion slots: At least 4 PCI	
	Optical drive type: Slim SATA DVD-RW	
	Network Adapter: 1/10 Gb, 4 Ports	
	Smart Array: Include 2GB Flash Backed Write Cache	
	USB Ports: 2 USB 3.0	
	Hot Swappable Disks with RAID capability	
	System Management ó Capability to use an integrated installer for rapid installation and configuration of Softwareø. The system shall provide monitoring of both hardware and software performance, server deployment, vulnerabilities, thermal and system power among other core functionalities.	
	Form factor - Rack Mountable	
Support: Include manufacturerø 24 x 7 combined hardware support		
Power Supply: The servers shall use the existing KPLC UPS system at the Network Operation Center NOC located on 7 th Floor at Stima Mall.		
Warranty Support - Parts/Labor/Onsite. 3-year labor, 3-year onsite-24*7, 4-hour response time, warranty onsite, in-country, spare parts and material to be provided including disk Retention.		

		<p><u>Support Requirements</u> As a minimum, the following hardware and software support services are expected to be provided by the manufacturers of the systems:</p> <ol style="list-style-type: none"> 1. Assigned account support in-charge and specialist personnel(s). 2. Remote support for proactive system management. 3. Post-Commissioning account support plan (<i>i.e. start of the support period</i>). 4. System availability checkups 5. Software updates 6. Periodic planning and reviews of the support activity 7. Electronic information support. 8. Storage/Server firmware and software analysis and management 9. OS/OE patches analysis and management 10. Server firmware, micro-code updates 11. Storage array high availability assessment. 12. Capacity building. 13. Escalation and Contact management. 14. Commitments in response time. 15. Immediate response/intervention by certified hardware and software specialists. 16. Support for ad-hoc specific technical services related to management of security, availability, change, capacity, and infrastructure. 17. In-country spare parts stocking and inventory management. 18. Access to manufacturers support and knowledge web sites. <p>Tenderers to supply a list of services being provided by them in these areas</p>	
	NMS Database Server	Microsoft SQL or Oracle or MYSQL	
2	OPERATING SOFTWARE		
	NMS SERVER Operating system, software and All licenses needed		

3	OPTICAL NETWORK MONITORING SYSTEM (NMS) SOFTWARE		
	i. Fiber Network Monitoring	Monitor dark fiber network. Monitor live fiber network. Monitor diverse fiber network types <i>(Long Haul, Metro & FTTH/x - PONs)</i> Intrusion detection Monitoring SLA for leased fibers. <i>(Service Availability etc.)</i> RTU Site Monitoring Event logging provide 24/7/365 basis Easy view of fiber performance - GUI Monitoring terminals at three (3) sites	
	ii. Alarm Management	Comply with the ITU X733 Standard , Detection and isolation of faults <ul style="list-style-type: none"> • High loss points • Kinks • Fiber cuts, • Reflectance Change, • Attenuation, • Fiber Extension, • Optical Return Loss Change ó etc. Filter Alarms, Classification of alarms based on severity Alarm Notifications - <i>Email, SMS etc.)</i> Monitor progress of Alarm status. Alarm Display Configuration - <i>Real-time, History</i> Alarm Clear & Acknowledgement Export to ó PDF <i>or</i> Excel	
	iii. Alarm Details	Optical distance to fault Reference to landmark locations GPS coordinates of fault location Attenuation at the fault	
	iv. User Management	User configuration by functional groups /Domain(s); On-duty scheduling / calendar integration; User access to Web GUI via username and password. Audit log on of user activities	

	v. Test Configuration	Reference trace Comparison	
		Test definition and scheduling (recurrence interval);	
		Test-On-Demand (TOD) and view;	
	vi. Domain Views	Partitioned/layered network views	
		Fibers and RTU can belong to multiple domains	
		Views based on Metros, Customers, regional and entire fiber network	
	vii. Supported Modules	SNMP	
		GIS Interface, Mapping and Integration	
		Web Browser Access	
		Smartphone / SMS Access and configuration	
	viii. Auto Discovery	Automatic discovery of RTUs including details (interfaces, OTDR Specs, Number of Optical Switch Ports, Connected ports).	
		Pre-determined discovery schedule (Days, Hours, Minutes etc.)	
		Discovery can run across a specific domain / function group	
	ix. Inventory Scanning	Automated scan keeps fiber and RTU database up to-date and eliminates manual intervention	
		Synchronization process with RTUs	
		Auto identification and recording of any changes detected within the Fiber Network	
	x. Reports and Documentation	Short-term and long-term network performance	
		SLA performance per link	
		<i>Network availability</i>	
		The reports can be generated and exported to pdf and excel via email	
		Contract Management	
		Service availability & performance reports	
		Domain based reports	
4	REMOTE TEST UNIT		
	i. General	Height	Bidder to specify

Specifications	Width	To fit in 19" Swing-out Rack Cabinet	
	Depth	The depth to allow swing out for ease of rear access.	
	Operating Temperature	0 to 50°C	
	Storage Temperature	0 to 60°C	
	Humidity	95% non-condensing	
	EMI/ESD	CE Compliant	
ii. OTDR Module Specifications	Interfaces	Support for LAN & WAN Connectivity	
	Storage Media	Solid State Disk ó SSD, Capacity ×80GB	
	Module	Front Panel Plug in Module	
	Applicable Fiber	Single mode (G652, G655)	
	Wavelength:	1310,1550 nm,1625nm, 1650nm	
	Pulse optical output:	Ö+ 15 dBm	
	Dynamic range:	> 45dB	
	Distance range:	from 2.6m up to 400 km	
	Pulse width:	× 3 ns	
	Sampling Data Points	up to 250,000	
	Attenuation Dead Zone	Ö5m	
	Event Dead Zone	Ö0.8m	
	Laser safety standard:	1M (IEC 60825-1)	
	Valid Calibration Certificate.		
	iii. Optical Switch Module	Module	Front Panel Plug in Module or External Expansion Module
Number of Ports		24	
Connector Type		FC/UPC	
Wavelength		1260 nm ó 1700 nm	

		Insertion loss:	Ö0.6dB	
		Switch speed:	**	
		Durability:	× 100 million cycles	
		Repeatability	Ö0.02 dB	
	iv. Communication	Ethernet Ports	2	
		Wireless Interface Card/ Module	GSM	
		IP Support	IPv4, IPv6	
		WEB Server	Inbuilt	
		Thin Client	Web Browser Access	
	v. Power Supply	Power Supply	Equipment to operate on existing - 48VDC at KPLC substations.	
	vi. Warranty	3 Years (<i>Parts & Labor</i>)		
5	DESKTOP COMPUTER			
		Monitors	Ergonomic articulating arms	
			24' Dual multi-screen	
			VGA, DVI and HDMI connectors	
		Desktop	1 TB 7200rpm SATA internal drive	
			Windows 7 or higher, 64-bit OS	
			RAM: 4GB DDR3	
			Graphics 2 GB Dedicated	
			Processor: Intel core i5 2.5 GHz, Dual core	
		Warranty	3 Years	
6	MAINTENANCE LAPTOP			
		i. Display	13.3 inch LED backlight, 2560X1600 pixel (Retina) per inch	
		ii. Cache	4 MB or Higher	
		iii. Interface	HDMI PORT	
		iv. Processor	Intel Core i7 Processor Dual-Core Clock Speed of 2.5 GHz 64-bit Computing	
		v. RAM	8 GB DDR3	
		vi. Graphics	2 GB Dedicated	

		vii. Battery	Built-in, standby 5 (five) Hours.	
		viii. Voltage	240V	
		ix. Operating system	Preinstalled Genuine Windows 8.1® Pro 64 Bit with Restore media kit or preinstalled restore partition to restore to factory settings	
		x. Optical Drive	DVD-Writer - Tray	
		xi. Hard Drive	500 GB SATA 5400 rpm	
		xii. Camera	720p HD	
		xiii. Display	15 inch WXGA anti-glare (1080 x 1920 resolution)	
		xiv. Connectivity	Bluetooth, Wi-Fi,	
		xv. Integrated Wired	Intel Gigabit Network Connection (10/100/1000 NIC)	
		xvi. Integrated Wireless	802.11, Bluetooth 4.0	
		xvii. Data Link Protocol	Bluetooth 4.0, Ethernet, Fast Ethernet, IEEE 802.11a, IEEE 802.11ac, IEEE 802.11b, IEEE 802.11g, IEEE 802.11n	
		xviii. Integrated Security	Security Lock Slot plus steel cable with a combination lock	
		xix. Connection and Expansions	2 x USB 2.0 USB 3.0 LAN HDMI Headphone/microphone combo jack Support SD Memory Card	
		xx. Input	101/102 Key compatible keyboard Touchpad with scroll zone	

		xxi. Warranty	1 Year or more on Warranty		
		xxii. Power	6 Cell lithium ion Battery; External AC adapter		
		xiii. Power Supply	240V AC, 50 Hz, British plugs		
		xiv. Carrying Case	Genuine Leather Carrying Case		
7	GRAPHIC DISPLAY				
	Screen	Voltage	240V, 50Hz		
		Display		55' HD-LED backlight commercial-grade w/ integrated speakers	
				1920 X 1080 Res	
				16;9 aspect ratio, 50/60 Hz refresh rate	
		Connectivity		displayable colors; more than 16.7million	
				PC signal compatibility	
		Input terminals		Macintosh Compatibility	
				Digital: Display port, HDMI, DVI-D	
				Analogue: VGA 15-pin D-sub, 5 BNC	
		External control		RS-232C, RJ45, IR remote, DDC/CI	
		Output terminals		DVI-D, RS 2323C	
		Power		ON: 100W, Standby Mode: <2W	
	Mounting		free standing video for a three (3) screen mount		
	Warranty		3 Years parts & labor		
8	SERVER CABINET				
		Standards	IEC 60529		
		Height	42 U		
		Depth	Ö900mm		
		Width	19"		
		Color	RAL 9005		
14	RTU CABINET				
		Standard	IEC 62208,		

		Color	RAL 7035	
		Protection Class	IEC 60529 6 IP 54	
		Height	42 U	
		Depth	Ö900mm	
		Width	19"	
		Power Supply Kit	15A Outlet Strip with 6 front mounted receptacles	
		Cubicle Lighting		
		Cable management	Steel Ring Panel for 19ö Mounting, Vertical Cable management fittings	
		Accessories	Detachable ground, fan, rack unit label	
		Front Door	Steel Frame with glass panel	
		Front Offset	150mm	
		Cooling		
		Frame mount	<i>Swing-out min 120 degrees</i>	
		Cable Entry	Top and Floor entry with cable (<i>protective covers</i>).	
16	TRAINING			
	Equipment training for 6 Engineers at Manufacturers premises for a minimum 40hrs (<i>8hrs/day for 5-days</i>)			
	Factory Acceptance Test at Manufacturers premises for 3 Officers-(<i>FAT</i>)			
	Operator training and On the Job, local training for 10 staff			

SECTION XI - DRAWINGS

Figure 1: Architecture of Proposed KPLC Network

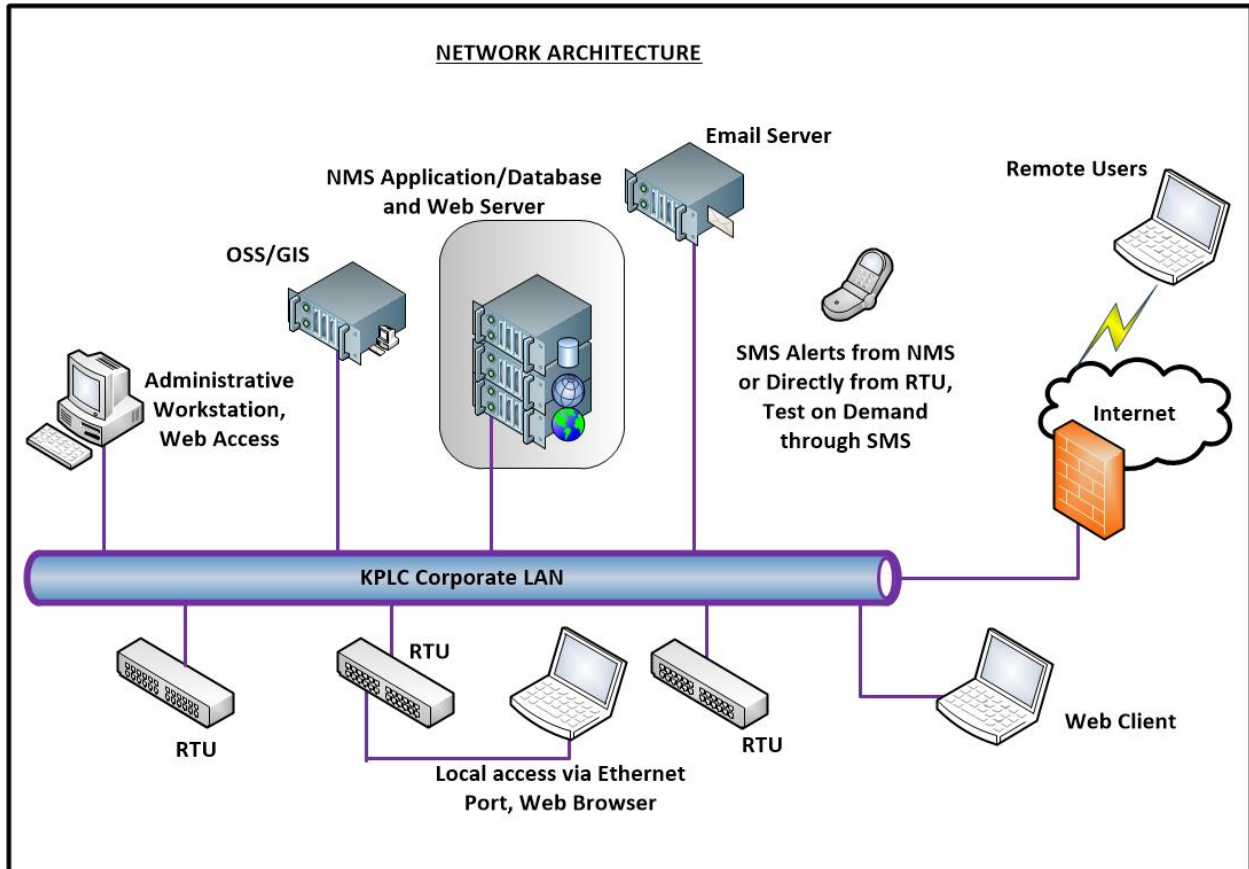

SECTION XII - STANDARD FORMS

- (i) Tender Form
- (ii) Confidential Business Questionnaire
- (iii) Tender Security Form (Bank Guarantee)
- (iv) Tender Security Form (Institutions)
- (v) Tender Security Form (Letter of Credit)
- (vi) Manufacturers Authorisation Form
- (vii) Manufacturer's Warranty Form
- (viii) Declaration Form
- (ix) Letter of notification of award
- (x) Letter of notification of regret
- (xi) Contract Agreement Form
- (xii) Performance Security Form (Bank Guarantee)
- (xiii) Performance Security Form (LC)
- (xiv) Letter of Acceptance
- (xv) Qualification Information Forms
- (xvi) Details of Proposed Sub-Contractors
- (xvii) Site Visit Form
- (xviii) Manufacturers Authorisation Form
- (xix) Supplier Performance Rating Form

(i) - TENDER FORM

Date:í í í í í í í í

Tender Noí í í í í í í

To:

The Kenya Power & Lighting Company Limited,
Stima Plaza,
Kolobot Road, Parklands,
P.O Box 30099 ó 00100,
Nairobi, Kenya.

Ladies and Gentlemen,

1. Having read, examined and understood the Tender Document including all Addenda, the receipt of which is hereby duly acknowledged, we, the undersigned Tenderer, offer to supply, deliver, install and commission *(the latter two where applicable)* *(insert goods description)* in accordance and conformity with the said tender document for the sum of í í í í í í *.(total tender amount inclusive of all taxes in words and figures)* or such sums as may be ascertained in accordance with the Price Schedule attached herewith and made part of this Tender.
2. We undertake, if our Tender is accepted, to deliver, install and commission the goods in accordance with the delivery schedule specified in the Schedule of Requirements.
3. If our Tender is accepted, we will obtain the performance security of a licensed commercial bank in Kenya in a sum equivalent to ten percent (10%) of the contract price for the due performance of the contract, in the form(s) prescribed by The Kenya Power & Lighting Company Limited.
- 4.* We agree to abide by this Tender for a **period of.....days (Tenderer please indicate validity of your tender)** from the date fixed for tender opening as per the Tender Document, and it shall remain binding upon us and may be accepted at any time before the expiration of that period.
5. This Tender, together with your written acceptance thereof and your notification of award, shall not constitute a contract, between us. The contract shall be formed between us when both parties duly sign the written contract.

6. We understand that you are not bound to accept any Tender you may receive.

Yours sincerely,

Name of Tenderer

Signature of duly authorised person signing the Tender

Name and Designation of duly authorised person signing the Tender

Stamp or Seal of Tenderer

***NOTES:**

1. KPLC requires a validity period of at least ninety (90) days.
2. This form must be duly completed, signed, stamped and/or sealed.

Part 2 (a) Sole Proprietor

Your name in full í .

Nationality í í í í í í í í í Country of origin í í í í í í í í í í ..

*Citizenship details í .

Part 2 (b) Partnership

Give details of partners as follows: -

Names	Nationality	*Citizenship Details	Shares
1. í			
2. í			
3. í			
4. í .			
5. í .			

Part 2 (c) Registered Company

Private or Public í .

State the nominal and issued capital of company-

Nominal KSh. í í í í í í í í í í í í í í í í í

Issued KSh í í í í í í í í í í í í í í í í í

Give details of all directors as follows

Name	Nationality	*Citizenship Details	Shares
1. í .			
2. í .			
3. í ..			
4. í ..			

Part 2 (d) List of Associated Companies Participating in this Tender

Give details as follows: -

Name of Company	Country of Registration	Directors	Shares (%)
1. í ..			
2. í .			
3. í ..			
4. í .			

Name of duly authorized person to sign for and on behalf of the Tenderer .. í í í í í í í í í ..

Designation of the duly authorized person í í í í í í í í í í í í í

Signature of the duly authorized person í í í í í í í í í í ..

***NOTES TO THE TENDERERS ON THE QUESTIONNAIRE**

1. *The address and contact person of the Tenderer provided above shall at all times be used for purposes of this tender.*
2. *If a Kenyan citizen, please indicate under “Citizenship Details” whether by birth, naturalization or registration.*
3. *The details on this Form are essential and compulsory for all Tenderers. **Failure to provide all the information requested shall lead to the Tenderer’s disqualification.***
4. *For foreign Tenderers please give the details of nominal and issued share capital in the currency of the country of origin of the Tenderer.*

(iii) - TENDER SECURITY FORM – (BANK GUARANTEE)

(To Be Submitted On Bank’s Letterhead)

Date:

To:

The Kenya Power & Lighting Company Limited,
Stima Plaza,
Kolobot Road, Parklands,
P.O Box 30099 ó 00100,
Nairobi, Kenya.

WHEREAS í í í í í í í í í í í í í í í (name of the Tenderer) (hereinafter called “the Tenderer”) has submitted its Tender dated í í í for the supply, installation and commissioning off í í í í í í í í í í (please insert KPLC tender no. and name) (hereinafter called “the Tender”);

KNOW ALL PEOPLE by these presents that **WE** í í í í í í í í í í í í í í í .of í í í í í í í í í í .having our registered office atí í í í í í í í í í .(hereinafter called “the Bank”), are bound unto The Kenya Power and Lighting Company Limited (hereinafter called “KPLC” which expression shall where the context so admits include its successors-in-title and assigns) in the sum of í í í í í í í í í í í í í í . for which payment well and truly to be made to the said KPLC, the Bank binds itself, its successors, and assignees by these presents.

We undertake to pay you, upon your first written demand declaring the Tenderer to be in breach of the tender requirements and without cavil or argument, the entire sum of this guarantee being í í í í í í í í í í .. (amount of guarantee) as aforesaid, without you needing to prove or to show grounds or reasons for your demand or the sum specified therein.

This tender guarantee will remain in force up to and including thirty (30) days after the period of tender validity, and any demand in respect thereof should reach the Bank not later than the date below.

This guarantee is valid until the í ..í day offí í í í í í í í í í 20í í

EITHER

SEALED with the)
COMMON SEAL)

of the said **BANK**) _____
this 1 1 1 1 1 1 1 1 day) **BANK SEAL**
of 1 1 1 1 1 1 1 1 1 1 201 .)

in the presence of :-)
)
_____)

and in the presence of:-)
)
_____)

OR

SIGNED by the **DULY AUTHORISED**
REPRESENTATIVE(S)/ ATTORNEY(S) of
the **BANK**

Name(s) and Designation of duly authorised representative(s)/ attorney(s) of the Bank

Signature(s) of the duly authorised person(s)

NOTES TO TENDERERS AND BANKS

- Please note that no material additions, deletions or alterations regarding the contents of this Form shall be made to the Tender Security to be furnished by the Tenderer. If any are made, the Tender Security shall not be accepted and shall be rejected by KPLC. For the avoidance of doubt, such rejection will be treated as non-submission of the Tender Security where such Security is required in the tender.*

2. *It is the responsibility of the Tenderer to sensitize its issuing bank on the need to respond directly and expeditiously to queries from KPLC. The period for response shall not exceed three (3) days from the date of KPLC's query. Should there be no conclusive response by the Bank within this period, such Tenderer's Tender Security shall be deemed as invalid and the bid rejected.*
3. ***The issuing bank should address its response or communication regarding the bond to KPLC at the following e-mail address – “guarantees@kplc.co.ke”***
4. *The Tender validity period is ninety (90) days as set out in the Invitation to Tender (at Section I of the Tender document) or as otherwise may be extended by KPLC. Therefore the Tender Security must at all times be valid for at least 30 days beyond the tender validity period.*

(iv)

TENDER SECURITY FORM (SACCO SOCIETY, DEPOSIT TAKING MICRO FINANCE INSTITUTIONS, WOMEN ENTERPRISE FUND & YOUTH ENTERPRISE FUND)

(To Be Submitted On Institutions Letterhead)

Date:

To:

The Kenya Power & Lighting Company Limited,
Stima Plaza,
Kolobot Road, Parklands,
P.O Box 30099 ó 00100,
Nairobi, Kenya.

WHEREAS í í í í í í í í í í (hereinafter called òthe Contractorö) has undertaken, in pursuance of your Tender Number í í í í í ..(*reference number of the Tender*) and its Tender dated(*insert Contractor’s date of Tender taken from the Tender Form*) to supply í í í í í (*description of the Works*) (hereinafter called òthe Contract);

AND WHEREAS it has been stipulated by you in the said Contract that the Contractor shall furnish you with an Institution’s guarantee by an acceptable Institution for the sum specified therein as security for compliance of the Contractor’s performance obligations in accordance with the Contract;

AND WHEREAS we have agreed to give the Contractor a Guarantee;

THEREFORE WE HEREBY AFFIRM that we are Guarantors and responsible to you, on behalf of the Contractor, up to a total of í í í í í í í í . (*amount of the guarantee in words and figures*) and we undertake to pay you, upon your first written demand declaring the Contractor to be in default under the Contract and without cavil or argument, any sum or sums within the limits of í í í í í í í í í í í í í í í ... (*amount of guarantee*) as aforesaid, without you needing to prove or to show grounds or reasons for your demand or the sum specified therein.

This guarantee is valid until the í í í í day of í í í í í í .í ..í 20í .

EITHER

SEALED with the)

COMMON SEAL)

of the said **INSTITUTION**)

)

this í í í í í í í í day)

)

INSTITUTION SEAL

of í í í í í í í í 20í .)

in the presence of :-)

)

_____)

)

and in the presence of:-)

)

_____)

OR

SIGNED by the **DULY AUTHORISED REPRESENTATIVE(S)/ ATTORNEY(S)** of the **INSTITUTION**

Name(s) and Designation of duly authorised representative(s)/ attorney(s) of the **Institution**.

Signature(s) of the duly authorised person(s)

NOTES TO SUPPLIERS AND INSTITUTIONS

- Please note that no material additions, deletions or alterations regarding the contents of this Form shall be made to the Tender Security to be furnished by the Tenderer. If any are made, the Tender Security shall not be accepted and shall be*

rejected by KPLC. For the avoidance of doubt, such rejection will be treated as non-submission of the Tender Security where such Security is required in the tender.

2. *It is the responsibility of the Tenderer to sensitize its issuing institution on the need to respond directly and expeditiously to queries from KPLC. The period for response shall not exceed three (3) days from the date of KPLC's query. Should there be no conclusive response by the institution within this period, such Tenderer's Tender Security shall be deemed as invalid and the bid rejected.*

3. ***The issuing institution should address its response or communication regarding the Tender Security to KPLC at the following e-mail address – “guarantees@kplc.co.ke”***

4. *The Tender validity period is one hundred and twenty (120) days as set out in the Invitation to Tender (at Section I of the Tender document) or as otherwise may be extended by KPLC. Therefore the Tender Security must at all times be valid for at least 30 days beyond the tender validity period.*

(v) TENDER SECURITY – (LETTERS OF CREDIT)

The Mandatory Conditions to be included in the Letters are in two parts, A and B.

Part A

Form of Documentary credit - ðIrrevocable Standbyö

Applicable rules - ðMust be UCP Latest Versionö i.e. Uniform Customs and Practices (UCP) 600 (2007 REVISION) ICC Publication No. 600.

Place of expiry - At the counters of the advising bank.

The SBLC should be available – ðBy Paymentö

Drafts should be payable at - ðSIGHTö

Documents required -

1. Beneficiaryø signed and dated statement demanding for payment under the letter of credit noí í í í í í í í í í .. *(Insert LC No.)* así í í í í í í í í í .*(Name of applicant)* (hereinafter called the ðTendererö) indicating that the ðTenderer” has defaulted in the obligations of the Tenderer as stated by the Beneficiary.
2. The Original Letter of Credit and all amendments, if any.

Additional Conditions -

1. All charges levied by any bank that is party to this documentary credit are for the account of the applicant.
2. There should be no conditions requiring compliance with the specific regulations or a particular countryø Law and regulations.

Charges - All bank charges are for the account of the applicant.

*Confirmation instructions ó (See notes below)

Part B

The proceeds of these Letters are payable to KPLC -

- a) if the Tenderer withdraws its Tender after the deadline for submitting Tenders but before the expiry of the period during which the Tenders must remain valid.
- b) if the Tenderer rejects a correction of an arithmetic error
- c) if the Tenderer fails to enter into a written contract in accordance with the Tender Document

- d) if the successful Tenderer fails to furnish the performance security in accordance with the Tender Document.
- e) if the Tenderer fails to extend the validity of the tender security where KPLC has extended the tender validity period in accordance with the Tender Document.

NOTES TO TENDERERS AND BANKS

1. *Please note that should the Tender Security (LC) omit any of the above conditions the LC shall not be accepted and shall be rejected by KPLC. For the avoidance of doubt, such rejection will be treated as non-submission of the LC where such LC is required in the Tender.*
2. *It is the responsibility of the Tenderer to sensitize its issuing bank on the need to respond directly and expeditiously to any queries from KPLC. The period for response shall not exceed three (3) days from the date of KPLC's query. Should there be no conclusive response by the Bank within this period, such Tenderer's Tender Security shall be deemed as invalid and the bid rejected.*
3. ***The issuing bank should address its response or communication regarding the bond to KPLC at the following e-mail address – “guarantees@kplc.co.ke”***
4. *The Tender validity period is one hundred and twenty (120) days as set out in the Invitation to Tender (at Section I of the Tender document) or as otherwise may be extended by KPLC. Therefore the Tender Security must at all times be valid for at least 30 days beyond the tender validity period.*
5. *All Guarantees issued by foreign banks must be confirmed by a local bank in Kenya.*

(vi) - MANUFACTURER’S AUTHORIZATION FORM

(To Be Submitted On Manufacturer’s Letterhead)

To:

The Kenya Power & Lighting Company Limited,
Stima Plaza, Kolobot Road, Parklands,
P.O Box 30099 6 00100,
Nairobi, Kenya.

WHEREAS WE í í í í í í í í í í í (*name of the manufacturer*) who are established and reputable manufacturers of í í í í í í í í í í (*name and description of the goods*) having factories at(*full address and physical location of factory(ies) where goods to be supplied are manufactured*) do hereby confirm that í í í í í í í í í í í í í í í (*name and address of Supplier*) is authorized by us to transact in the goods required against your Tender í í í í í í í í í í í í (*insert reference number and name of the Tender*) in respect of the above goods manufactured by us.

DATED THIS í í í í í .. DAY OF í í í í í í í í í í í í .20í í

Signature of duly authorised person for and on behalf of the Manufacturer.

Name and Designation of duly authorised person signing on behalf of the Manufacturer

NOTES TO TENDERERS AND MANUFACTURERS

Only a competent person in the service of the Manufacturer should sign this letter of authority.

(vii) - MANUFACTURER’S WARRANTY FORM

To Be Submitted On Manufacturer’s Letterhead)

To:

The Kenya Power & Lighting Company Limited,
Stima Plaza, Kolobot Road, Parklands,
P.O Box 30099 6 00100,
Nairobi, Kenya.

RE: MANUFACTURER’S WARRANTY FOR GOODS REQUIRED UNDER TENDER NO TO BE SUPPLIED BY(indicate your name or the supplier you have authorized)

WE HEREBY WARRANT THAT:

- a) The goods to be supplied under the contract are new, unused, of the most recent or current specification and incorporate all recent improvements in design and materials unless provided otherwise in the Tender.
- b) The goods in the Tenderer’s bid have no defect arising from manufacture, materials or workmanship or from any act or omission of the Tenderer that may develop under normal use of the goods under the conditions obtaining in Kenya.

This warranty will remain valid for the period indicated in the special conditions of contract after the goods, or any portion thereof as the case may be, have been delivered, installed and commissioned at the final destination indicated in the contract.

DATED THIS DAY OF .20

Signature of duly authorised person for and on behalf of the Manufacturer.

Name and Designation of duly authorised person signing on behalf of the Manufacturer

NOTES TO TENDERERS AND MANUFACTURERS

- 1. *Only a competent person in the service of the Manufacturer should sign this letter of authority.*
- 2. *Provide full contact details including physical address, e-mail, telephone numbers and the website on the Warranty.*

(viii) - DECLARATION FORM

Date _____

To:

The Kenya Power & Lighting Company Limited,
 Stima Plaza,
 Kolobot Road, Parklands,
 P.O Box 30099 6 00100,
 Nairobi,
KENYA.

Ladies and Gentlemen,

The Tenderer i.e. (full name and complete physical and postal address) _____
 _____ declare the following: -

- a) That I/ We have not been debarred from participating in public procurement by anybody, institution or person.
- b) That I/ We have not been involved in and will not be involved in corrupt and fraudulent practices regarding public procurement anywhere.
- c) That I/We or any director of the firm or company is not a person within the meaning of paragraph 3.2 of ITT (Eligible Tenderers) of the Instruction to Bidders.
- d) That I/ We are not insolvent, in receivership, bankrupt or in the process of being wound up and is not the subject of legal proceedings relating to the foregoing.
- e) That I/ We do hereby confirm that all the information given in this Tender is accurate, factual and true to the best of our knowledge.
- f) That I/ We are not associated with any other Tenderer participating in this tender

Yours sincerely,

Name of Tenderer_____
Signature of duly authorised person signing the Tender_____
Name and Designation of duly authorised person signing the Tender_____
Stamp or Seal of Tenderer

(x) - LETTER OF NOTIFICATION OF REGRET

To: (Name and full address of the Unsuccessful Tenderer).....

Date:

Dear Sirs/ Madams,

RE: NOTIFICATION OF REGRET IN RESPECT OF TENDER NO.

We refer to your Tender dated í í í í í í and regret to inform you that following evaluation, your Tender is unsuccessful. It is therefore not accepted. The brief reasons are as follows:-

- 1. í í í í í í í í í
- 2. í í í í í í í í í
- 3. í í í í í í í í í etcí

The successful bidder was _____.

However, this notification does not reduce the validity period of your Tender Security. In this regard, we request you to relook at the provisions regarding the Tender Security, Signing of Contract and Performance Security as stated in the Instructions to Tenderers.

You may collect the tender security from our *Legal Department (Guarantees Section)*, on the 2nd Floor, Stima Plaza, Kolobot Road, Parklands, Nairobi only after expiry of **twenty five (25) days** from the date hereof on Mondays and Wednesdays ONLY between 9.00 a.m to 12.30 pm and 2.00p.m to 4.00p.m.

It is expected that by that time KPLC and the successful bidder will have entered into a contract pursuant to the Public Procurement and Asset Disposal Act, 2015 (or as may be amended from time to time or replaced). When collecting the Security, you will be required to produce the original **or certified copy** of this letter.

We thank you for the interest shown in participating in this tender and wish you well in all your future endeavours.

Yours faithfully,

FOR: THE KENYA POWER & LIGHTING COMPANY LIMITED

GENERAL MANAGER, SUPPLY CHAIN

(xi) - CONTRACT AGREEMENT FORM

THIS AGREEMENT made this.....day of.....**20....** **BETWEEN THE KENYA POWER & LIGHTING COMPANY LIMITED**, a limited liability company duly incorporated under the Companies Act, Chapter 486 of the Laws of Kenya, with its registered office situated at Stima Plaza, Kolobot Road, Parklands, Nairobi in the Republic of Kenya and of Post Office Box Number 30099-00100, Nairobi in the Republic aforesaid (*hereinafter referred to as "KPLC"*) of the one part,

AND

..... (*Contractor's full name and principal place of business*) a duly registered entity according to the laws of..... (*state country*) and of Post Office Box Number.....(*full address physical and postal of Contractor*) in the Republic aforesaid, (*hereinafter referred to as the "Contractor"*) of the other part;

WHEREAS KPLC invited tenders for certain works, that is to say for (*KPLC Supply Chain – Procurement Department insert description of Works*) under Tender Number..... (*KPLC Supply Chain – Procurement Department insert tender number*)

AND WHEREAS KPLC has accepted the Tender by the Contractor for the services in the sum of (*KPLC Supply Chain – Procurement Department _ specify the total amount in words which should include any payable taxes, duties and insurance where applicable e.g. Value Added Tax*) (*hereinafter called "the Contract Price"*).

NOW THIS AGREEMENT WITNESSETH AS FOLLOWS: -

1. In this Agreement words and expressions shall have the same meanings as are respectively assigned to them in the Conditions of Contract and the Tender Document.
2. Unless the context or express provision otherwise requires: -
 - a) reference to "this Agreement" includes its recitals, any schedules and documents mentioned hereunder and any reference to this Agreement or to any other document includes a reference to the other document as varied supplemented and or replaced in any manner from time to time.
 - b) any reference to any Act shall include any statutory extension, amendment, modification, re-amendment or replacement of such Act and any rule, regulation or order made thereunder.

- c) the Official Purchase Order shall also mean the Official Order or Local Purchase Order.
 - d) words importing the masculine gender only, include the feminine gender or (as the case may be) the neutral gender.
 - e) words importing the singular number only include the plural number and vice-versa and where there are two or more persons included in the expression the “*Contractor*” the covenants, agreements obligations expressed to be made or performed by the Contractor shall be deemed to be made or performed by such persons jointly and severally.
 - f) where there are two or more persons included in the expression the “*Contractor*” any act default or omission by the Contractor shall be deemed to be an act default or omission by any one or more of such persons.
3. In consideration of the payment to be made by KPLC to the Contractor as hereinbefore mentioned, the Contractor hereby covenants with KPLC to perform and Contractor in consideration of the execution, completion, and maintenance of the Works by the Contractor as prescribed by the Contract provide the services and remedy any defects thereon in conformity in all respects with the provisions of the Contract.
 4. KPLC hereby covenants to pay the Contractor in consideration of the proper performance and provision of the services and the remedying of defects therein, the Contract Price or such other sum as may become payable under the provisions of the Contract at the times and in the manner prescribed by the Contract.
 5. The following documents shall constitute the Contract between KPLC and the Contractor and each shall be read and construed as an integral part of the Contract: -
 - a) this Contract Agreement
 - b) Letter of Acceptance dated í í í í ..
 - c) General Conditions of Contract
 - d) Special Conditions of Contract
 - e) Official Purchase Order where applicable
 - f) Technical Specifications
 - g) Drawings
 - h) Bill of Quantities/Schedule of Requirements
 - i) Implementation Plan (work methods and schedule)
 - j) KPLC's Notification of Award dated í í í í
 - k) Tender Form signed by the Contractor
 - l) Declaration Form signed by the Contractor/ successful Tenderer
 - m) Warranty

6. In the event of any ambiguity or conflict between the contract documents listed above, the order of precedence shall be the order in which the contract documents are listed in 5 above except where otherwise mutually agreed in writing.
7. The Commencement date shall be the working day immediately following the fulfillment of all the following: -
 - a) Execution of this Contract Agreement by KPLC and the Contractor.
 - b) Issuance of the Performance Bond by the Contractor and confirmation of its authenticity by KPLC.
 - c) Issuance of the Official Order by KPLC to the Contractor.
 - d) Where applicable, Opening of the Letter of Credit by KPLC.
8. The period of contract validity shall begin from the Commencement date and end at the expiry of the Defects Liability Period.
Provided that the expiry period of the Warranty shall be as prescribed and further provided that the Warranty shall survive the expiry of the contract.
9. It shall be the responsibility of the Contractor to ensure that its Performance Security is valid at all times during the period of contract validity and further is in the full amount as contracted.
10. Any amendment, change, addition, deletion or variation howsoever to this Contract shall only be valid and effective where expressed in writing and signed by both parties.
11. No failure or delay to exercise any power, right or remedy by KPLC shall operate as a waiver of that right, power or remedy and no single or partial exercise of any other right, power or remedy.
12. Notwithstanding proper completion of performance or parts thereof, all the provisions of this Contract shall continue in full force and effect to the extent that any of them remain to be implemented or performed unless otherwise expressly agreed upon by both parties.
13. Any notice required to be given in writing to any Party herein shall be deemed to have been sufficiently served, if where delivered personally, one day after such delivery; notices by electronic mail shall be deemed to be served one day after the date of such transmission and delivery respectively, notices sent by post shall be deemed served seven (7) days after posting by registered post (*and proof of posting shall be proof of*

service), notices sent by courier shall be deemed served two (2) days after such receipt by the courier service for Local contractors and five (5) days for Foreign contractors.

14. For the purposes of Notices, the address of KPLC shall be Company Secretary, The Kenya Power & Lighting Company Limited, 7th Floor, Stima Plaza, Kolobot Road, Post Office Box Number 30099600100, Nairobi, Kenya. The address for the Contractor shall be the Contractor's address as stated by it in the Confidential Business Questionnaire provided in the Tender Document.

IN WITNESS whereof the parties hereto have caused this Agreement to be executed in accordance with the laws of Kenya the day and year first above written.

SIGNED for and on behalf
of **THE KENYA POWER & LIGHTING COMPANY LIMITED**

MANAGING DIRECTOR & CEO

and in the presence of:-

COMPANY SECRETARY

SEALED with the **COMMON SEAL**
of the **CONTRACTOR**
in the presence of:-

DIRECTOR

Affix Contractor's Seal here

DIRECTOR'S FULL NAMES

and in the presence of:-

DIRECTOR/ COMPANY SECRETARY

DIRECTOR/ COMPANY SECRETARY'S FULL NAMES

DRAWN BY: -

Awuor Owiti

Advocate,

C/o The Kenya Power & Lighting Company Limited,

7th Floor, Stima Plaza,

Kolobot Road, Parklands,

Post Office Box Number 30099600100,

NAIROBI, KENYA,

Telephones: + 254-20-3201000/ 731

Facsimile: + 254-20-3514485/ 3750240

(xii) PERFORMANCE SECURITY FORM (BANK GUARANTEE)

(To Be Submitted On Bank’s Letterhead)

Date:

To:

The Kenya Power & Lighting Company Limited,
Stima Plaza,
Kolobot Road, Parklands,
P.O Box 30099 ó 00100,
Nairobi, Kenya.

WHEREAS í í í í í í í í í í (hereinafter called òthe Contractorö) has undertaken, in pursuance of your Tender Number í í í í í ..(*reference number of the Tender*) and its Tender dated(*insert Contractor’s date of Tender taken from the Tender Form*) to supply í í í í í (*description of the works*) (hereinafter called òthe Contract);

AND WHEREAS it has been stipulated by you in the said Contract that the Contractor shall furnish you with a bank guarantee by an acceptable bank for the sum specified therein as security for compliance of the Contractor’s performance obligations in accordance with the Contract;

AND WHEREAS we have agreed to give the Contractor a guarantee;

THEREFORE WE HEREBY AFFIRM that we are Guarantors and responsible to you, on behalf of the Contractor, up to a total sum of í í í í í í í í . (*amount of the guarantee in words and figures*) and we undertake to pay you, upon your first written demand declaring the Contractor to be in default under the Contract and without cavil or argument, any sum or sums within the limits of í í í í í í í í í í í í í í í í ... (*amount of guarantee*) as aforesaid, without you needing to prove or to show grounds or reasons for your demand or the sum specified therein.

This guarantee is valid until the í í í í day of í í í í í í .í ..í 20í .

EITHER

SEALED with the)
COMMON SEAL)
of the said **BANK**)
)
this í í í í í í í í í í day)

_____)
 of í í í í í í í í í 20í .)
 in the presence of :-)
 _____)
 _____)
 and in the presence of:-)
 _____)
 _____)

BANK SEAL

OR

**SIGNED by the DULY AUTHORISED
 REPRESENTATIVE(S)/ ATTORNEY(S) of
 the BANK**

 Name(s) and Designation of duly authorised representative(s)/ attorney(s) of the Bank

 Signature(s) of the duly authorised person(s)

NOTES TO CONTRACTORS AND BANKS

1. *Please note that no material additions, deletions or alterations regarding the contents of this Form shall be made to the Performance Security Bond (the Bond) to be furnished by the successful Tenderer/ Supplier. If any are made, the Bond may not be accepted and shall be rejected by KPLC. For the avoidance of doubt, such rejection will be treated as non-submission of the Bond where such Bond is required in the tender and Contract.*
2. *KPLC shall seek authentication of the Performance Security from the issuing bank. It is the responsibility of the Contractor to sensitize its issuing bank on the need to respond directly and expeditiously to queries from KPLC. The period for response shall not exceed three (3) days from the date of KPLC’s query. Should there be no conclusive response by the Bank within this period, such Contractor’s Performance Security may be deemed as invalid and the Contract nullified.*
3. ***The issuing Bank should address its response or communication regarding the bond to KPLC at the following e-mail address – “guarantees@kplc.co.ke”***

(xiii) - PERFORMANCE SECURITY (LC)***Mandatory Conditions that should appear on the Performance Security (LC).*****Form of Documentary credit -** ðIrrevocable Standbyö**Applicable rules -** ðMust be UCP Latest Versionö i.e. UCP 600 (2007 REVISION) ICC Publication No. 600.**Place of expiry -** At the counters of the advising bank.**The SBLC should be available –** ðBy Paymentö**Drafts should be payable at -** ðSIGHTö**Documents required -**

1. Beneficiary's signed and dated statement demanding for payment under the letter of credit no. í í í í í í í í í .. (*Insert LC No.*) así í í í í í í í í í .(*Name of Applicant*) (hereinafter called the ðContractorö) indicating that the ðContractorö has defaulted in the performance and adherence to and performance of the contract between the Beneficiary and the Contractor.
2. The Original Letter of Credit and all amendments, if any.

Additional Conditions -

1. All charges levied by any bank that is party to this documentary credit are for the account of the Applicant.
2. (Include) that there should be no conditions requiring compliance with the specific regulations or a particular country's laws and regulations.

Charges - All bank charges are for the account of the Applicant.

Confirmation instructions ó (See notes below)

NOTES TO CONTRACTORS AND BANKS

1. *Please note that should the Performance Security (LC) omit any of the above conditions the LC shall not be accepted and shall be rejected by KPLC. For the avoidance of doubt, such rejection will be treated as non-submission of the LC where such LC is required in the tender and Contract.*

2. *KPLC may seek authentication of the Performance Security (LC) from the issuing bank. It is the responsibility of the Contractor to sensitize its issuing bank on the need to respond directly and expeditiously to queries from KPLC. The period for response shall not exceed three (3) days from the date of KPLC's query. Should there be no conclusive response by the Bank within this period, such Contractor's Performance Security (LC) may be deemed as invalid and the Contract nullified.*
3. ***The issuing bank should address its response or communication regarding the bond to KPLC at the following e-mail address – “guarantees@kplc.co.ke”***
4. *All Guarantees issued by foreign banks must be confirmed by a local bank in Kenya.*

(xiv) - LETTER OF ACCEPTANCE

[Letter-head paper of the Employer]

_____ [date]

To: _____
[name of the Contractor]

[address of the Contractor]

Dear Sir,

This is to notify you that your Tender dated _____
for the execution of _____
[name of the Contract and identification number, as given in the Tender documents] for the
Contract Price of (Indicate Currency) _____ [amount in figures]
(Indicate Currency) _____ (amount in words)] in accordance
with the Instructions to Tenderers is hereby accepted.

You are hereby instructed to proceed with the execution of the said Works in accordance with
the Contract documents.

Authorized Signature í

Name and Title of Signatory í

Attachment : Agreement

(xv) QUALIFICATION INFORMATION

1. Individual Tenderers or Individual Members of Joint Ventures

1.1 Constitution or legal status of tenderer (attach copy or Incorporation Certificate)

Place of registration: _____

Principal place of business _____

Power of attorney of signatory of tender _____

1.2 Total annual volume of construction work performed in the last three years

Year	Volume	
	Currency	Value
Year 1		
Year 2		
Year 3		

1.3 Work performed as Main Contractor on works of a similar nature and volume over the last three years. Also list details of work under way or committed, including expected completion date.

Project Name	Name of Client and contact person (Address & Telephone No.)	Type of Work performed and year of completion	Value of contract

1.4 Major items of Contractor's Tools & Equipment proposed for carrying out the Works. List all information requested below. (Attach evidence of ownership or lease)

Item of Tools & Equipment	Description, Make and age (years)	Condition (new, good, poor) and number available	Owned, leased (from whom?), or to be purchased (from whom?)

- 1.5 Qualifications and experience of key personnel proposed for administration and execution of the Contract as required by Subsection 3.20 of the Instructions to Tenderer, Attach biographical data.

Bidders should provide the names of suitably qualified personnel.

1.	Title of position*
	Name
2.	Title of position*
	Name
3.	Title of position*
	Name
4.	Title of position*
	Name

Resume for **each** Proposed Personnel

The data on their experience should be supplied using the Form below for each candidate.

Name of Bidder

Position		
Personnel information	Name	Date of birth
	Professional qualifications	
Present employment	Name of employer	
	Address of employer	
	Telephone	Contact (manager / personnel officer)
	Fax	E-mail
	Job title	Years with present employer

Summarize professional experience in reverse chronological order. Indicate particular technical and managerial experience relevant to the project.

From	To	Company / Project / Position / Relevant technical and management experience

1.6 Proposed Subcontractors for works

As per the requirements of Clause 3.20 of Conditions of Contract, following is a list of subcontractors and the portions of the Work to be subcontracted:

The following Subcontractors and/or manufacturers are proposed for carrying out the item of the facilities indicated. Bidders are free to propose more than one for each item

Sections of the Works	Value of Subcontract	Subcontractor (name and address)	Experience in similar work

1.7 Financial reports for the last three years: balance sheets, profit and loss statements, auditor's reports, etc. List below and attach copies of audited financial statements.

1.8 Evidence of access to financial resources to meet the qualification requirements: cash in hand, lines of credit, etc. List below and attach copies of supportive documents.

- 1.9 Name, address and telephone, telex and facsimile numbers of banks and/or institution that may provide reference if contacted by the Employer.

- 1.10 Statement of compliance with the requirements the Instructions to Tenderers.

- 1.11 Proposed program (work method and schedule) in compliance with requirement in the Instructions to Tenderers. Descriptions, drawings and charts, as necessary, to comply with the requirements of the tendering documents.

2 Joint Ventures

- 2.1 The information listed in 1.1 ó 1.10 above shall be provided for each partner of the joint venture.

- 2.2 The information required in 1.11 above shall be provided for the joint venture.

- 2.3 Attach the power of attorney of the signatory(ies) of the tender authorizing signature of the tender on behalf of the joint venture

- 2.4 Attach the Agreement among all partners of the joint venture (and which is legally binding on all partners), which shows that:

- a) all partners shall be jointly and severally liable for the execution of the Contract in accordance with the Contract terms;
- b) one of the partners will be nominated as being in charge, authorized to incur liabilities and receive instructions for and on behalf of any and all partners of the joint venture; and

- c) the execution of the entire Contract, including payment, shall be done exclusively with the partner in charge

(xvi) - SITE VISIT FORM

CONFIRMATION OF PRE-BID SITE VISIT

Name of Tenderer í í í í í í í í í í ..

Date of Visit í í í í í í í í í í í í í í

Name, position and signature of the Tenderer's staff visiting the site.

Name: í í í í í í í í í í í í í í í í ..

Position í í í í í í í í í í í í í í í í ..

Qualification

Signature í í í í í í í í í í í í í í Tenderer's Official Stamp í í í í í .

Site Visit conducted by Employer's Authorised Officer's

Name í í í í í í í í í í í í í í í í

Signature í í í í í í í í í í í í í í í í

SECTION XIII - SUPPLIER EVALUATION FORM

(This form is for information only and not to be filled in by any bidder. It is for official use by KPLC to evaluate performance of Suppliers during the contract period)

Name of Firm.....Date.....

Category: Works and Services

Period of evaluation 14 Days

1. COST OF SERVICE/PRODUCT	Rating guidelines				Supplier Score	Procurement Score	User Score	Comments	Totals
	Did the vendor assist in or advice on ways of reducing the costs?	YES:4	PARTIALLY:2	NO: 0					10
	How closely did your final costs correspond to your expectation at the beginning of the project/tender?	YES:2	PARTIALLY:1	NO: 0					10.00%
	Did the company stick to the agreed transaction/contract rates?	YES:4	PARTIALLY:2	NO: 0					
									Totals
2.ON TIME DELIVERY OF PRODUCT OR SERVICE									
	Did the vendor perform work in compliance with contract terms and agreements?	YES:6	PARTIALLY:3	NO: 0					10
	Was the vendor prompt and effective in correction of situations and conditions?	YES:2	PARTIALLY:1	NO: 0					10.00%
	Are you able to track service level agreements and determine duration of incidents from the vendor?	YES:2	PARTIALLY:1	NO: 0					
3. FLEXIBILITY TO RESPOND TO UNEXPECTED DEMAND OF SERVICE	Rating guidelines								Totals
	Was the vendor willing to change their product/service on special needs?	YES:6	PARTIALLY:3	NO: 0					6
									6.00%
4. QUALITY	Rating guidelines								Totals
	When performing their duties, was there - rework or returns caused by non-conformance to quality?	NO:6	PARTIALLY:3	YES: 0					14
	Was the quality of service delivered equal to KPLC minimum requirements?	YES:8	PARTIALLY:4	NO:0					14.00%
5.RESPONSIVENESS	Rating guidelines								Totals
	Was the vendor well responsive to information requests, issues, or problems that arose in the course of service?	YES:2	PARTIALLY:1	NO: 0					14
	Was the vendor open to feedback on low quality of service levels and willing to act on this?	YES:6	PARTIALLY:3	NO: 0					14.00%
	Is it easy to reach staff members of suppliers in case of a request or query? (are communication channels clear?)	YES:6	PARTIALLY:3	NO: 0					
6. CUSTOMER SUPPORT	Rating guidelines								Totals
	Did the vendor offer effective customer support?	YES:10	PARTIALLY:4	NO: 0					18
	In case of reported problems/issues, were there follow ups by the vendor to ensure the problem is fully resolved during support?	YES:8	PARTIALLY:4	NO: 0					18.00%
7.	Rating guidelines								Totals

COMMUNICATION SKILLS									
	Are you satisfied with the attitude, courtesy, and professionalism of this vendor's staff? Written or spoken?	YES:2	PARTIALLY:1	NO: 0				6	
	Are the vendor's staff well equipped and skilled in handling requests / issues? Are you rotated too much among staff on an issue?	YES:4	PARTIALLY:2	NO: 0				6.00%	
								Totals	
8. DOCUMENTATION AND ACCOUNTING		Rating guidelines							
	Are you satisfied with how the Vendor presents documentation (invoices & licenses etc.) when required to do so, to necessitate finalization of contract renewals and payments?	YES:6	PARTIALLY:3	NO: 0				10	
	Was problem documentation (incident reports) presented promptly by the vendor and was it complete?	YES:4	PARTIALLY:2	NO: 0				10.00%	
								Totals	
9. VALUE ADD		Rating guidelines							
	Did the vendor go over and above in optimizing service delivery process for effective services delivery?	YES:6	PARTIALLY:3	NO: 0				12	
	Did the vendor go over and above and offer training or knowledge to assist with better systems support?	YES:6	PARTIALLY:3	NO: 0				12.00%	
								Totals	
								Score:	
Totals								100.0	
Maximum Score								100.00%	
VENDOR'S TOTAL SCORE									
VENDOR'S PERCENTAGE SCORE									
ISSUES FOR FOLLOW UP -									
Evaluation Done									
by:		Name			Department			Date	
Checked/Validated									
by									

Score in Percentage %

PERFORMANCE LEVEL DEFINATION;

- ×75% - KP1 GREEN
- 50% - KP2 AMBER
- 25% - KP3 YELLOW
- ×25% - KP4 RED

RATING: 75% - V Good, 50% - Good, 25% - Fair, Below 25% - Poor

RECOMMENDATION

		Status	Tick as appropriate
1	Grant supplier preferred status	KP1	
2	Work with supplier or develop and improve supplier	KP2 & KP3	
3	Abandon / switch suppliers	KP4	

Name:.....Sign:.....Date:.....

Name:.....Sign:.....Date:.....

Name:.....Sign:.....Date:.....

APPENDIX 2: DETAILED NETWORK DIAGRAM

